



SUPER SACKER

10,000 Operator's & Parts Manual



Ideal Manufacturing, Inc. • 2011 Harnish Blvd. • Billings, MT 59101
P (406) 656-4360 / 800-523-3888 • F (406) 656-4363



2011 Harnish Blvd.
Billings, MT 59101

Phone: (406)656-4360/(800)523-3888
Fax: (406)656-4363

FAST-WAY LIMITED WARRANTY POLICY

Ideal Manufacturing, Inc., hereinafter referred to as "Manufacturer" warrants FAST-WAY equipment to be free from defect in material and workmanship, under normal use and service, for a period of one (1) year from the date of original purchase. Manufacturer will, at its option, replace or repair at factory in Billings, MT, any part or parts which shall appear, to the satisfaction of the Manufacturer, upon inspection at its factory, to have been defective in material or workmanship. This warranty does not obligate the Manufacturer to bear any transportation charges in connection with replacement or repair of defective parts. This warranty excludes electrical components and damage due to Acts of God, unauthorized modifications, misuse, abuse or negligence to this product.

In order to proceed with a warranty claim, Ideal Manufacturing must be notified of the problem. A new part will be shipped out prepaid (Ground UPS). If the customer requests that the part be expedited that shipping charge will be charged to the owner.

The part that is being warranted must be returned to Ideal Manufacturing postage prepaid. When the new part is shipped out, it will go out with an invoice and a warranty part return number. The defective part must be returned to Ideal Manufacturing, Inc freight prepaid, with the warranty part return number. At that time the invoice will be considered paid in full.

This warranty is exclusive and in lieu of all other obligation, liabilities or warranties. In no event shall Ideal Manufacturing be liable or responsible for incidental or consequential damage or for any other direct or indirect damage loss, cost, expense or fee.

This warranty shall not apply to any products or parts that have been altered or repaired without written consent of Ideal Manufacturing.

Labor to remove and reinstall defective product or parts will be paid from a labor rate and schedule only. Consult Ideal Manufacturing for that rate and schedule.

For further information on returning your product or questions concerning Ideal Manufacturing warranty, please contact Ideal Manufacturing.

NOTES

SAFETY RULES

1. Follow instructions, don't take chances. If you don't know, ask. When setting up, lowering or putting equipment into traveling position, follow all instructions in operator's manual.
2. Correct or report unsafe conditions. If not sure of how to correct a hazard, report it and get help.
3. Keep everything clean and orderly. Trips or falls can cause serious injuries.
4. Use the right tools and equipment for the job. Use them safely. Replace all machine guards after repair.
5. Report all injuries and get first aid or medical treatment promptly.
6. Use prescribed protective equipment. Keep it in good condition. Wear your hardhat, safety climbing devices or belt. Wear safe clothing to protect you from material being handled cold or hot. Wear a dust mask when conditions require them. When conditions require them, use gloves, eye protection/safety glasses, and earplugs for noise.
7. Use, adjust, and repair equipment only when authorized.
8. Remember, all petroleum fumes, gasoline, L.P. gasses are highly explosive.
9. Don't horseplay: avoid distracting others.
10. When lifting, bend your knees and get help for heavy loads.
11. Report all injuries and get first aid or medical treatment promptly.
12. Don't repair or adjust equipment while in motion. Shut off power source, gasoline engines or electric motors.
13. Comply with safety rules and signs.

SET UP PROCEDURE

1. Select a level site with a solid footing to set equipment on.
2. Set open side of the Super Sacker to the side that you want cement auger to face.
3. Put cement auger into place, align 10" flange of auger to 10" flange for Super Sacker.
4. Install boot and 2 hose clamps onto 10" flanges: SEE DRAWING SS102.
5. Loosen shipping bracket nuts on each corner of the load cell mount 1/16 of an inch: SEE FIGURE B.
6. To set up scale indicator and load cells: SEE separate MANUFACTURERS OWNER MANUAL.
7. Before loading hopper make sure 10" butterfly valve is closed.
8. This Super Sacker hopper system is set up to be used as a dissimulative weighing system. EXAMPLE:

If you have 7000lbs. of cement in your hopper and you are mixing a nine yard batch of 5 sacks which equals $9 \times 5 = 45 \times 94\text{lbs. cement} = 4,230\text{lbs.}$

You will need to discharge 4,230lbs. of cement from the 7000lbs. leaving 2,770lbs. of cement remaining in your Super Sacker hopper.

9. You will need to start the auger before you open the butterfly valve.
!WARNING!
If you open the butterfly valve before you start the auger you will harm the auger!
10. To ensure you get the correct mix you must empty the auger before you shut off the motor.
!WARNING!
If you shut the auger off before it is completely empty and proceed to start it up to resume the cement transfer, you will harm the auger!
11. When cement is to be left in Super Sacker hopper overnight or for an extended period of time, be sure to place lid on hopper.
12. For cement auger instructions: SEE CEMENT AUGER OWNERS MANUAL.

OPTIONAL EXTENSION SET UP PROCEDURE

SEE DRAWING SS102

1. Remove the lid off of the Super Sacker Hopper. Before installing extensions place a generous bead of silicone on top of the hopper frame where the extensions will sit.
2. Using a certified over head lifting chain or strap place it through the lifting eye on one of the 18 X 78 3/8 extensions.
3. Using a suitable lifting device, like a fork lift or crane, lift the extension and place it on top of the Super Sacker Hopper. Make sure the channel on the bottom of the extension sits on each side of the square tube frame of the Super Sacker Hopper, and slide down as far as possible.
4. Using a certified overhead lifting chain or strap place it through the lifting eye on one of the 18 X 72 extensions.
5. Using a suitable lifting device, like a fork lift or crane, lift the extension and place it on top of the Super Sacker Hopper. Make sure the channel on the bottom of the extension sits on each side of the square tube frame of the Super Sacker Hopper, and slide down as far as possible. Slide both of the extension together so the hole line up. Place the 3/8 bolts through one flat washer the extensions another flat washer lock washer, and 3/8 nut in all three holes. Leave the nut finger tight at this time.
6. Repeat steps 4 and 5 placing the remaining 18 X 72 extension across from the first 18 x 72 extension.
7. Repeat steps 2 and 3 placing the remaining 18 X 78 3/8 extension across from the first 18 X 78 3/8 extension. Place the 3/8 bolts through one flat washer the extensions another flat washer lock washer, and 3/8 nut in all six holes. Leave the nut finger tight at this time.
8. Place a generous bead of silicone in all four corners where the extensions meet inside, and out.
9. Tighten all nuts and bolts at this time.
11. Check to see that all of the extensions are sitting flat on top of the Super Sacker Hopper.
12. Place lid on top of extension. Let the silicone cure before using Super Sacker.

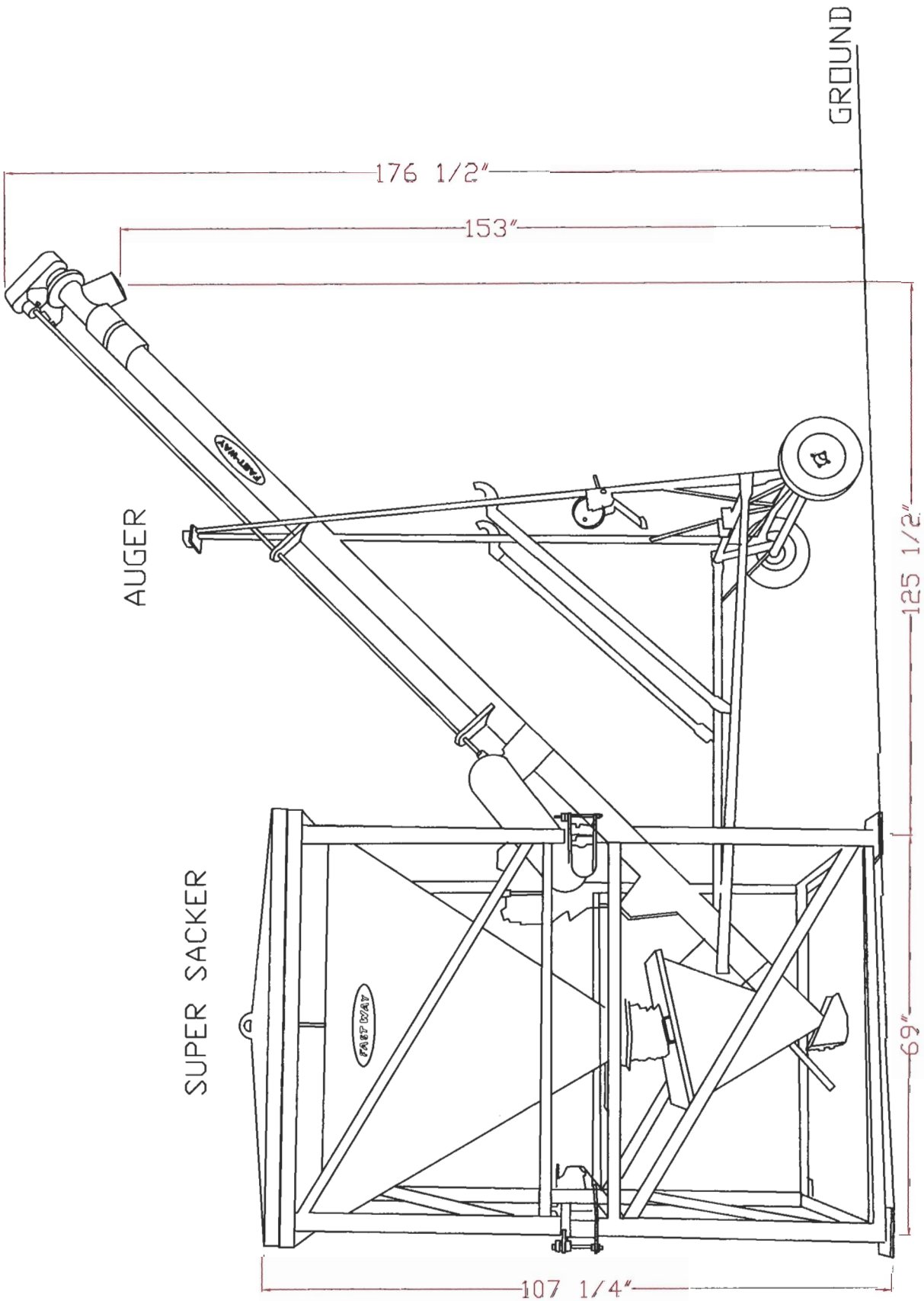

IDEAL MANUFACTURING INC.
 2011 HARNISH BLVD BILLINGS MT, 59101
 PHONE: (406)558-4360 FAX: (406)558-4363

FAST-WAY
 SUPER SACKER 10,000 CEMENT HOPPER
 SHOWN WITH FAST WAY AUGER
 CEMENT @ 94#/CU FT 20% FLUFF=75#/CU FT

SCALE: 1"=1' DRAWN BY: PAC DATE: 08/20/04 SHEET 1 OF 1

SUPER SACKER 10,000

SPECIFICATIONS

Capacity

Hopper	83 ft. ³ @ 94# = 7,800#	20% Fluff @ 75# = 6,200#
Optional		
Extension	54 ft. ³ @ 94# = 5,000#	20% Fluff @ 75# = 4,000#
Total Hopper and Optional Extension		
	137 ft. ³ @ 94# = 12,800	20% Fluff @ 75# = 10,200#

Scale System

- 4 5,000 lb. load cells
- 1 Digital weight indicator with 1/2" numbers
- 10" Butterfly discharge valve

Width	78"
Depth	85"
Height	112"
Height with extension on	130"
Weight	2,400lbs.
Shipping Volume	369 ft. ³

**FAST-WAY
SUPER SACKER 10,000 CEMENT HOPPER
PARTS LIST**

REF. NO.	PARTS NO.	DESCRIPTION	NO. OF
1	SSP101	Reinforced Lid with Lifting Eye	1
2	SSP100	Top Frame with Hopper	1
3	SSP102	Bottom Frame	1
4	POO380	10" Butterfly Valve	1
5	POO380A	32" Extension and Handle	1
6	SSP103	10" Valve Flange	1
7	POO192	Filler Boot Clamp	2
8	POO362	Filler Boot	1
9	SSP104	Weld Ring for Auger Lid	1
10	SSP104A	Auger Lid w/ Weld on Ring	1
11	NA	1/2-13 X 5 1/2" Bolt	8
12	NA	1/2" Lock Washer	8
13	NA	1/2-13 Hex Nut	8
14	NA	3/4-10 Hex Nut	24
15	SSP105	3/4-10 X 9 1/16" Ready Rod	4
16	POO920	Beam Load Cell Kit	1
17	POO902	Indicator Model 205	1
18	NA	5/8-11 X 2 1/2 BOLT	32
19	NA	5/8 Lock Washer	32
20	NA	5/8-11 Hex Nut	32
21	SSP106	Logo Plate	1

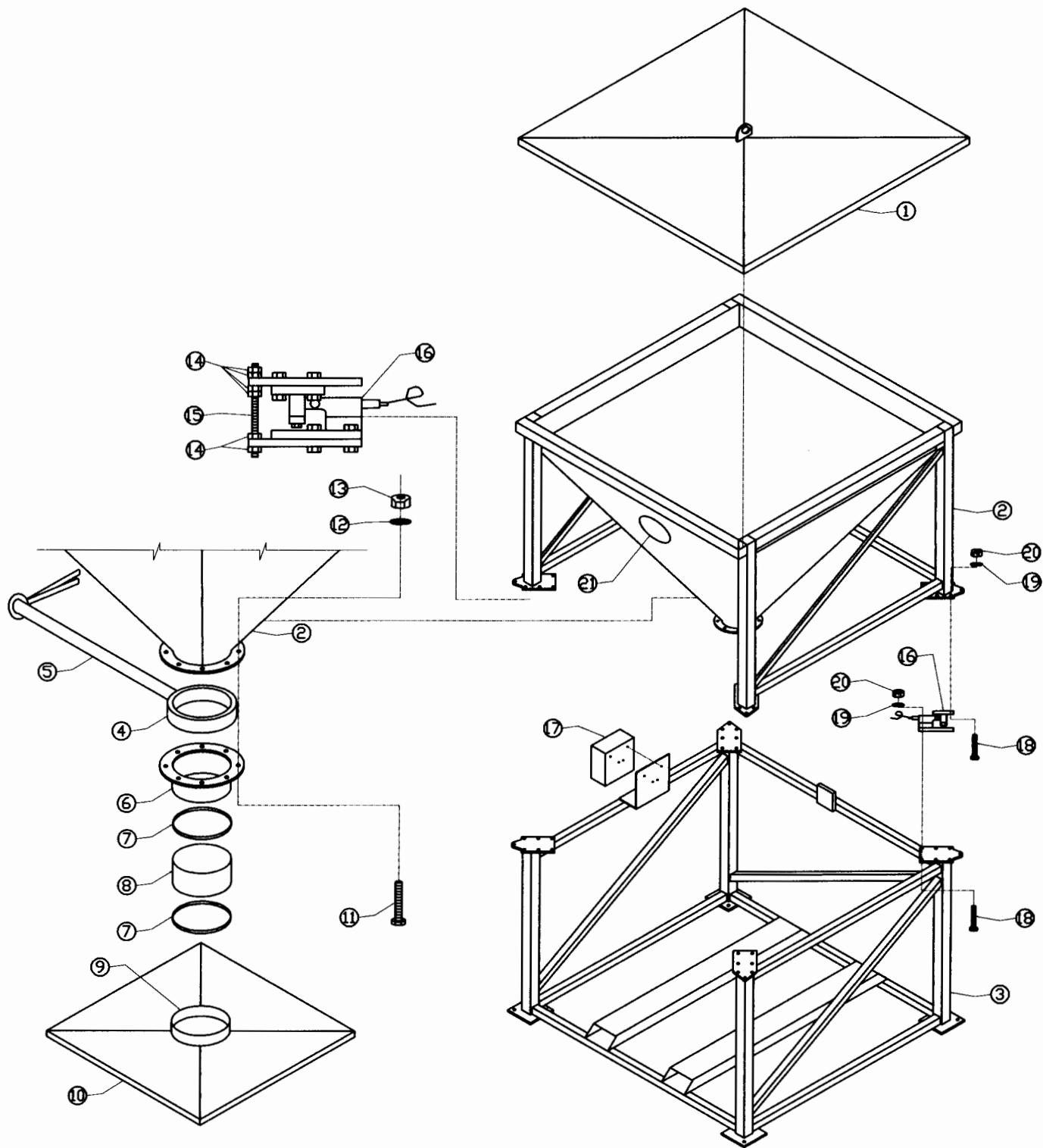

SERIAL NUMBER _____

IDEAL MANUFACTURING INC.

2011 HARNISH BLVD BILLINGS MT, 59101
 PHONE: (406)656-4360 FAX: (406)656-4363

WORK ORDER NO. _____

**FAST-WAY
 SUPER SACKER 10,000 CEMENT HOPPER**

NO SCALE DATE: 06-22-2005 SHEET 1 OF 1 DWN BY THH DWG #SS102

**FAST-WAY
SUPER SACKER 10,000 OPTIONAL EXTENSION
PARTS LIST**

REF. NO.	PARTS NO.	DESCRIPTION	NO. OF
1	SSP101	Reinforced Lid with Lifting Eye	1
2	SSP100	Top Frame with Hopper	1
3	NA	3/8-13 X 1 Bolt	12
4	NA	3/8 Flat Washer	24
5	NA	3/8 Lock Washer	12
6	NA	3/8-13 Hex Nut	12
7	SSP107	Hopper Extension 18 X 72	2
8	SSP108	Hopper Extension 18 X 78 3/8	2

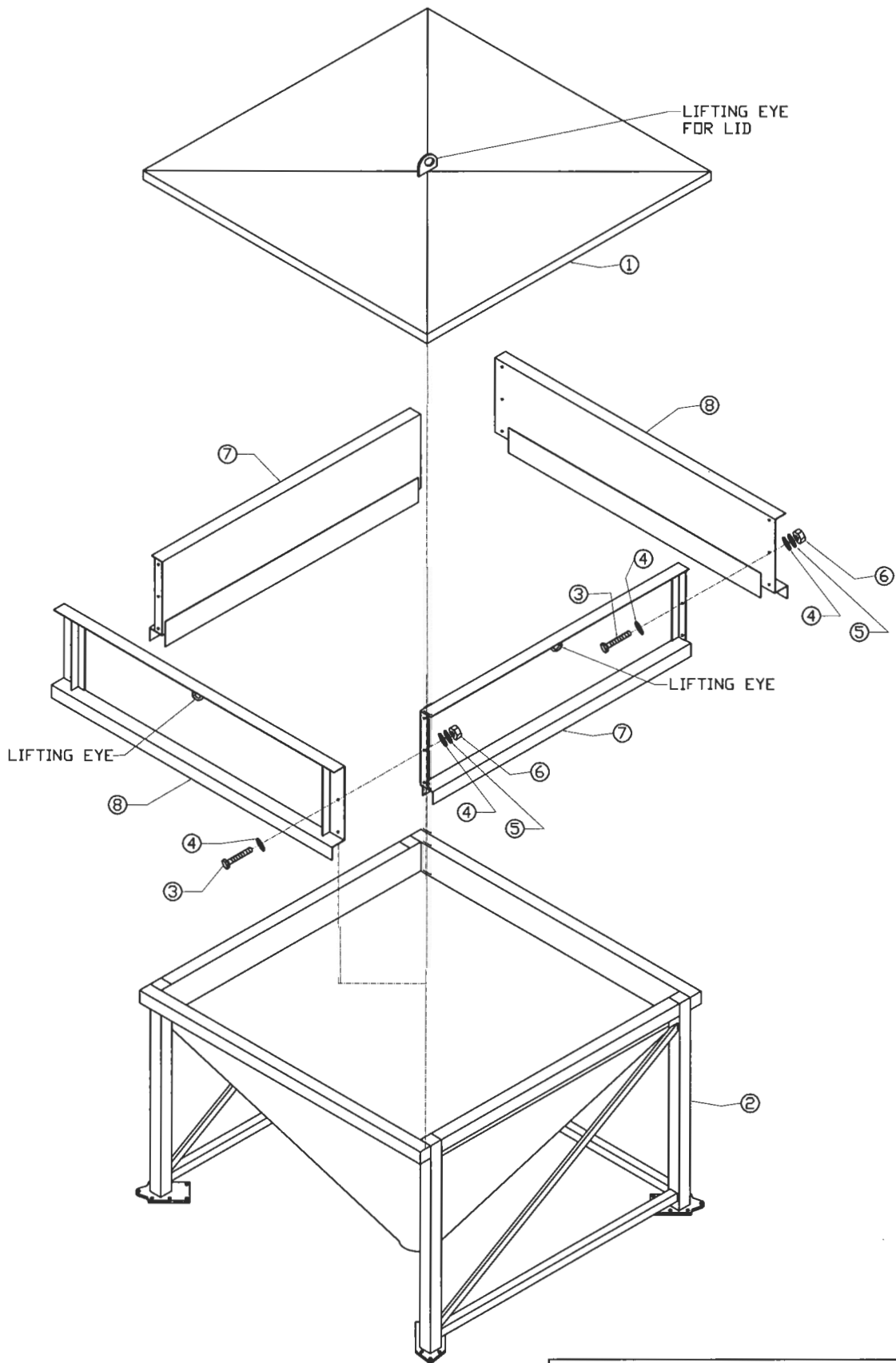

SERIAL NUMBER _____

IDEAL MANUFACTURING INC.	
2011 HARNISH BLVD BILLINGS MT, 59101	
PHONE: (406)656-4360 FAX: (406)656-4363	
WORK ORDER NO.	
FAST-WAY	
SUPER SACKER 10,000	
OPTIONAL CEMENT HOPPER EXTENSIONS	
NO SCALE	DATE:06-22-2005 SHEET 1 OF 1 DWN BY THH DWG #SS103

INSTALLATION INSTRUCTIONS

8000# SUPER SACKER CEMENT HOPPER FOUR SHEAR BEAM LOAD CELLS

1. DURING SHIPPING SEE FIG A

FIG A

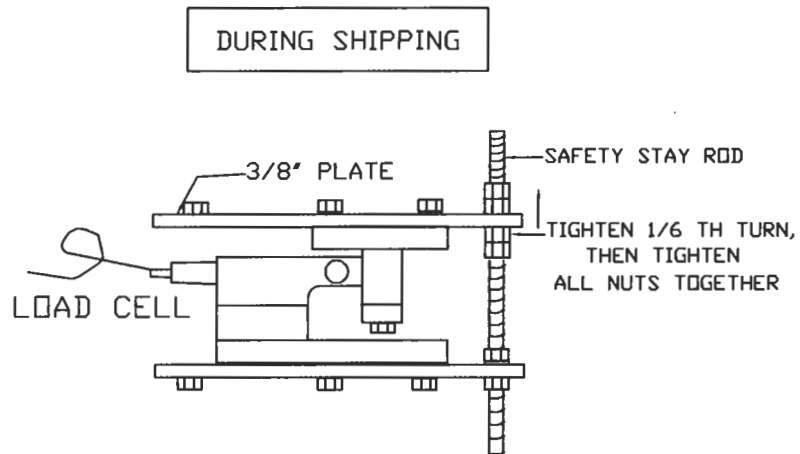

2. DURING OPERATION, SEE FIG B
TURN FOUR TOP NUTS AWAY FROM FLAT BAR 1/16"
TIGHTEN TOGETHER SEE BELOW

FIG B

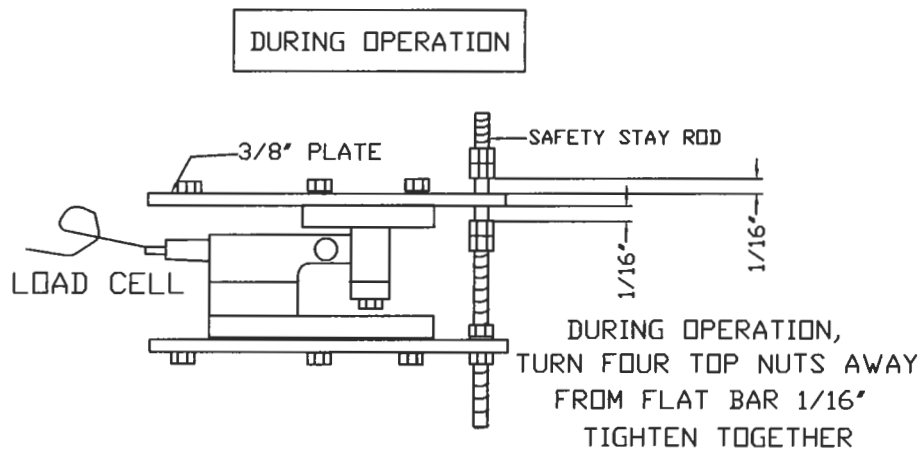

IDEAL MANUFACTURING INC.

DATE: 02-20-2002

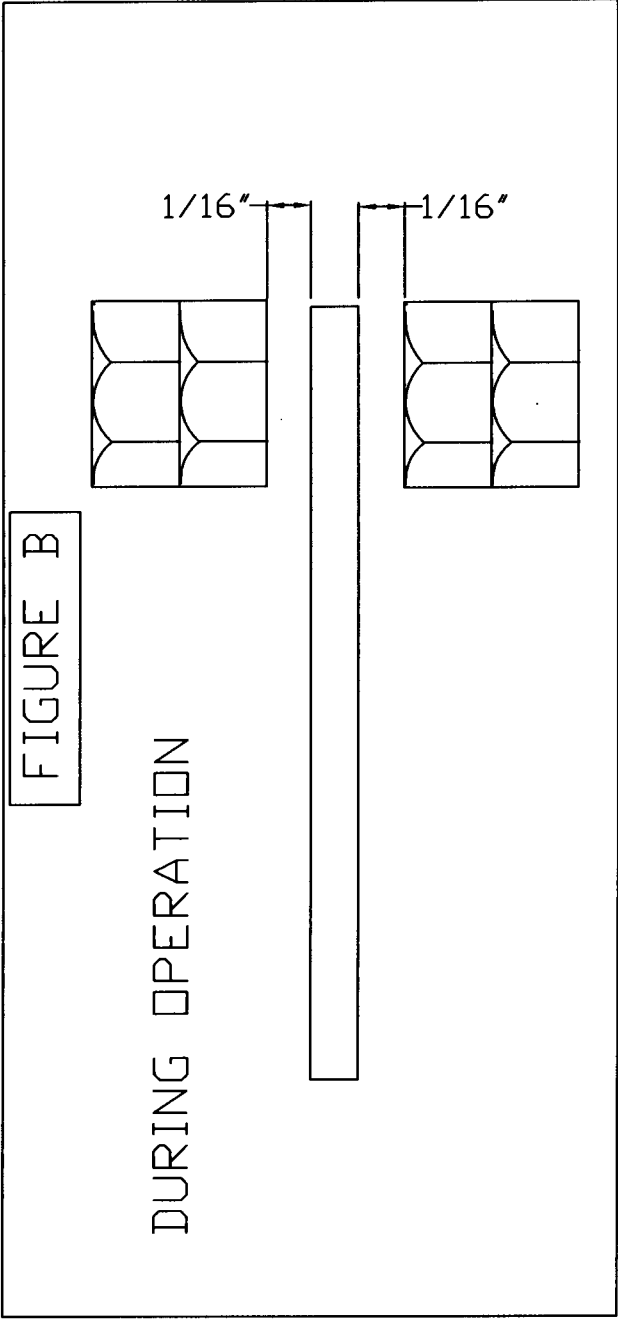
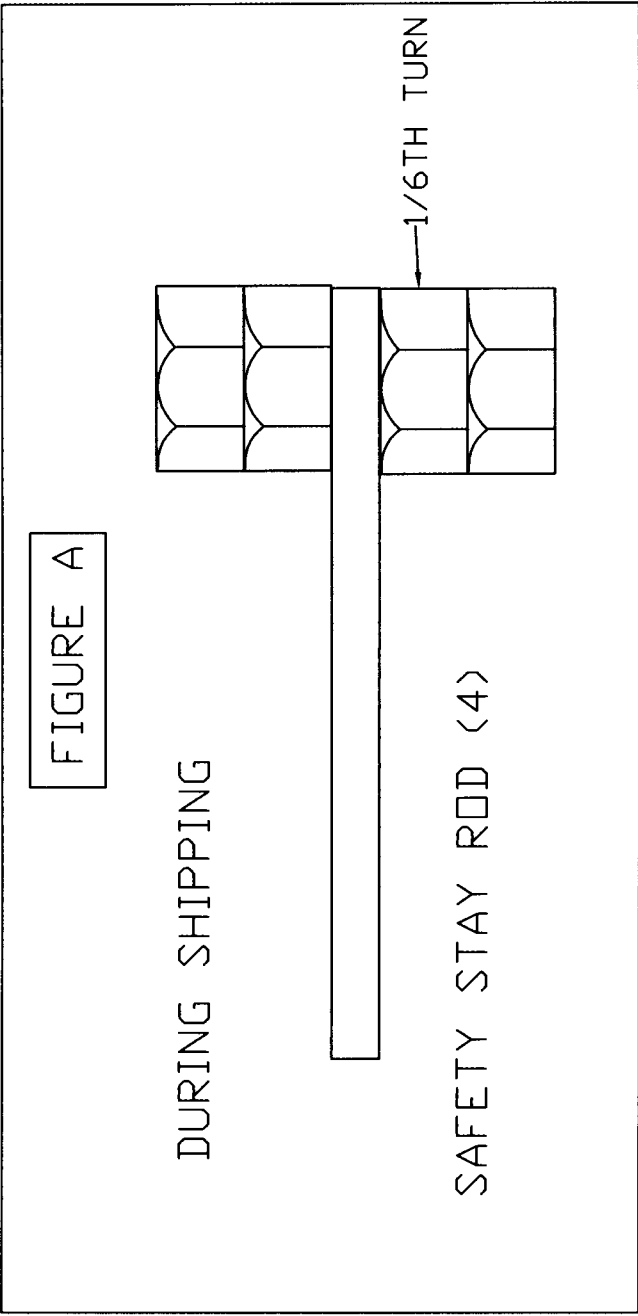

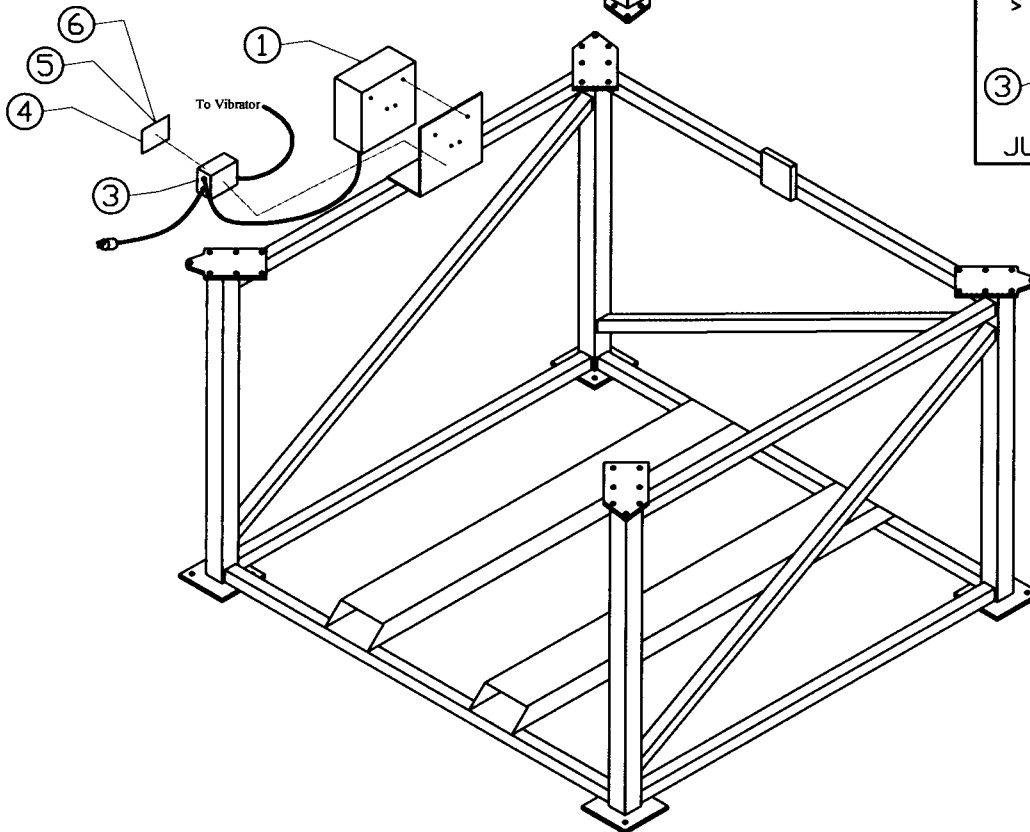
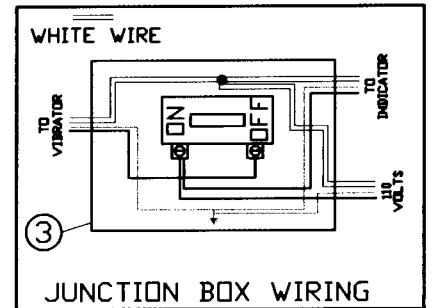
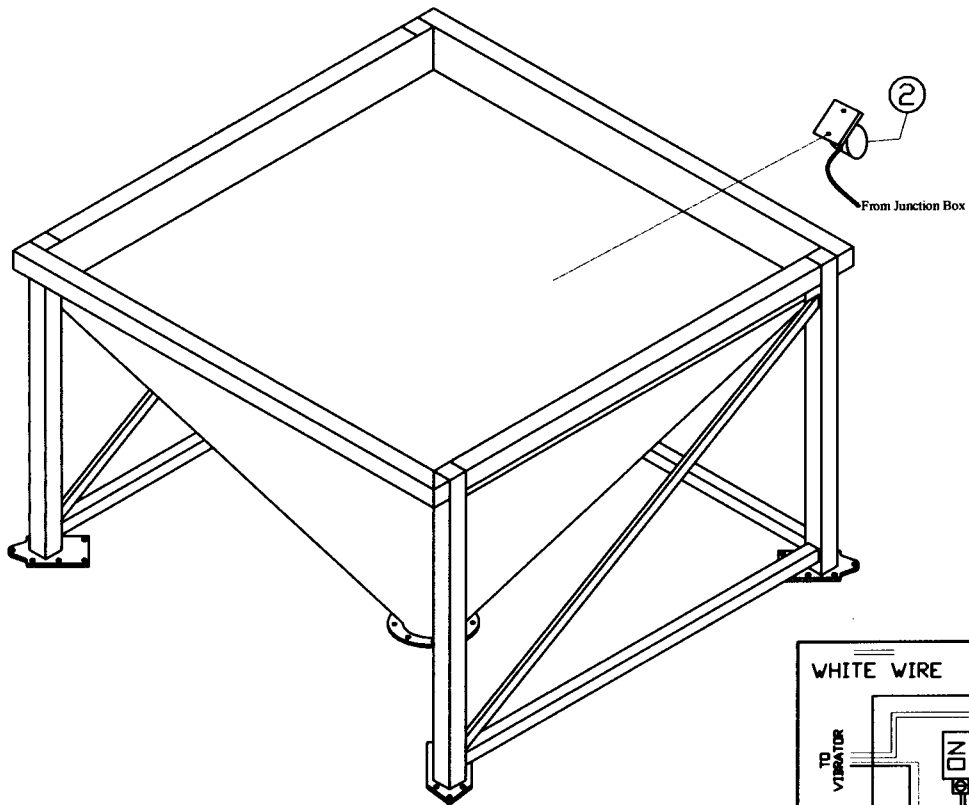

REF NO.	PART NO.	DESCRIPTION	REQ NO
1	POO902	Indicator Model 205	1
2	POO530	Vibrator (110 VAC)	1
	POO531	Vibrator (12 VDC)	1
3	PEO236	Junction Box	1
4	POO597	Switch with Cover Plate (110 VAC)	1
5	POO931	Switch (12 VDC)	1
6	PEO237	Cover Plate (12VDC)	1
7	PEO246	Strain Relief	3

IDEAL MANUFACTURING INC.

2011 HARNISH BLVD BILLINGS MT, 59101
 PHONE: (406)656-4360 FAX: (406)656-4363

WORK ORDER NO.

FAST-WAY
 SUPER SACKER 10,000 CEMENT HOPPER
 OPTIONAL VIBRATOR

NO SCALE DATE: 01-04-2008 SHEET 1 OF 1 DWN BY THH DWG #SSVID



205
WEIGHT INDICATING INSTRUMENT
Technical and Operation Manual

8200-M024-O1 Rev F
12/02

PO Box 151 • Webb City, MO 64870
Ph: 417-673-4631 • Fax: 417-673-5001
www.cardinalscale.com



Printed in USA

Technical Support: Ph: 866-254-8261 • techsupport@cardet.com

TABLE OF CONTENTS

STATIC ELECTRICITY PRECAUTION	Page 2
FCC COMPLIANCE STATEMENT	Page 2
SPECIFICATIONS	Page 3
Standard Features	Page 4
Additional Model 210 Features	Page 4
Optional Features	Page 4
Certifications	Page 4
EUROPEAN DECLARATION OF CONFORMITY	Page 5
PRECAUTIONS	Page 6
SITE PREPARATION REQUIREMENTS	Page 7
INSTALLATION	Page 8
MOUNTING	Page 8
LOAD CELL CONNECTION	Page 8
LOAD CELL CONNECTIONS WITH OVER 30 FEET OF CABLE	Page 9
LOAD CELL CABLE SHIELD WIRE CONNECTION	Page 9
SERIAL I/O CABLE INSTALLATION	Page 9
OPTICALLY ISOLATED INPUTS	Page 10
PRESET WEIGHT COMPARATOR/CHECKWEIGHER LOGIC LEVEL OUTPUT ..	Page 10
RELAY BOARD	Page 11
RE-INSTALLING THE REAR PANEL	Page 11
MAIN PCB JUMPERS (Figure No. 6)	Page 12
KEYPAD FUNCTIONS - Model 205	Page 13
ANNUNCIATORS - Model 205	Page 15
KEYPAD FUNCTIONS - Model 210	Page 16
ANNUNCIATORS - Model 210	Page 20
SETUP AND CALIBRATION	Page 22
SETUP REVIEW	Page 39
CALIBRATION "C" NUMBERS	Page 39
ACCUMULATORS	Page 40
BEFORE YOU CALL SERVICE	Page 41
ERROR CODES	Page 42
CALIBRATION SEAL INSTALLATION	Page 43
OPTIONAL BATTERY OPERATION	Page 44
APPENDIX A – ANALOG OUTPUT OPTION (DAC) BOARD	Page 47
PART IDENTIFICATION	Page 50

SERIAL NUMBER _____
DATE OF PURCHASE _____
PURCHASED FROM _____

RETAIN THIS INFORMATION FOR FUTURE USE

PRECAUTIONS

Before using this instrument, read this manual and pay special attention to all "WARNING" symbols:



IMPORTANT



**ELECTRICAL
WARNING**



**STATIC
SENSITIVE**

STATIC ELECTRICITY PRECAUTION



CAUTION! This device contains static sensitive circuit cards and components. Improper handling of these devices or printed circuit cards can result in damage to or destruction of the component or card. Such actual and/or consequential damage IS NOT covered under warranty and is the responsibility of the device owner. Electronic components must be handled only by qualified electronic technicians who follow the guidelines listed below:



ATTENTION! ALWAYS use a properly grounded wrist strap when handling, removing or installing electronic circuit cards or components. Make certain that the wrist strap ground lead is securely attached to an adequate ground. If you are uncertain of the quality of the ground, you should consult a licensed electrician.

ALWAYS handle printed circuit card assemblies by the outermost edges. NEVER touch the components, component leads or connectors.



ALWAYS observe warning labels on static protective bags and packaging and NEVER remove the card or component from the packaging until ready for use.

ALWAYS store and transport electronic printed circuit cards and components in anti-static protective bags or packaging.

FCC COMPLIANCE STATEMENT

WARNING! This equipment generates, uses and can radiate radio frequency and if not installed and used in accordance with the instruction manual, may cause interference to radio communications. It has been tested and found to comply with the limits for a Class A computing device pursuant to Subpart J of Part 15 of FCC rules, which are designed to provide reasonable protection against such interference when operated in a commercial environment. Operation of this equipment in a residential area may cause interference in which case the user will be responsible to take whatever measures necessary to correct the interference.

You may find the booklet "How to Identify and Resolve Radio TV Interference Problems" prepared by the Federal Communications Commission helpful. It is available from the U.S. Government Printing Office, Washington, D.C. 20402. Stock No. 001-000-00315-4.

All rights reserved. Reproduction or use, without expressed written permission, of editorial or pictorial content, in any manner, is prohibited. No patent liability is assumed with respect to the use of the information contained herein. While every precaution has been taken in the preparation of this manual, the Seller assumes no responsibility for errors or omissions. Neither is any liability assumed for damages resulting from use of the information contained herein. All instructions and diagrams have been checked for accuracy and ease of application; however, success and safety in working with tools depend to a great extent upon the individual accuracy, skill and caution. For this reason the Seller is not able to guarantee the result of any procedure contained herein. Nor can they assume responsibility for any damage to property or injury to persons occasioned from the procedures. Persons engaging the procedures do so entirely at their own risk.

SPECIFICATIONS

Power Requirements:	90 to 264 VAC (50/60 Hz) at 0.4A
Battery Operation:	CAM-350 Type 12 volt 2000 mAh (2.0 Ah)
Enclosure Type, Size:	NEMA 4X/IP66: 9 3/16"W x 7 1/2"H x 3 1/8"D (233mm W x 191mm H x 79mm D) Weight: 8.2lbs - (9.6lb with battery)
Operating Environment:	Temperature: 14 to 104 °F (-10 to +40 °C) Humidity: 90% non-condensing (maximum)
Display:	6-digit, 0.6" high, 7-segment LED
Transducer Excitation:	12 VDC (Jumper selectable) 8 VDC with battery operation (jumper selectable)
Signal Input Range:	1.0 mV min. to 40 mV max. (with dead load boost)
Number of Load Cells:	8 each, 350 OHM minimum resistance
Load Cell Cable Length:	1500 feet maximum. Consult factory for other requirements 30 feet maximum without sense lines
Division Value:	1, 2, or 5 x 10, 1, 0.1, 0.01, 0.001 and 0.0001 commercial 0 to 99, non-commercial
Sensitivity:	
NON-COMMERCIAL	0.15 uV/e
NTEP	0.3uV/e (Class III/IIIL)
CANADA	0.3uV/e (Class III/IIHD)
OIML	0.7 uV/e (Class III)
Scale Divisions:	
NON-COMMERCIAL	100 to 240,000
NTEP	100 to 10,000 (Class III/IIIL)
CANADA	100 to 10,000 (Class III/IIHD)
OIML	100 to 10,000 (Class III)
Internal Resolution:	1 part in 16,777,216
Tare Capacity:	Scale Capacity
Sample Rate:	1 to 100 samples per second, selectable
Auto Zero Range:	0.5 or 1 through 9 divisions
Weighing Units:	Tons, Pounds, Pounds-Ounces, Ounces, Metric Tons, Kilograms, Grams
Keypad:	Color coded Membrane type Model 205 - 7 keys Model 210 - 22 keys
Standard I/O:	(1) bi-directional RS232 (20mA) (1) output only RS232 (20mA)
Optional I/O:	14 bit Analog Output (0 to 10v, 4 to 20mA)

SPECIFICATIONS, Cont.

Standard Features:

- Push button tare function
- Gross, tare, net conversion
- Selectable key lockout
- Hi-Resolution mode
- Adjustable filtering
- Gross and Net accumulators
- Dual serial ports
- Remote input lines for Zero, Tare, Gross and Print (1000 feet maximum)
- Programmable print format using Visual Print or nControl (2 Visual Tickets available)
- SMA level 2 compliant serial communications
(For more information see <http://www.scalemanufacturers.org>)
- Field re-programmable via PC interconnection
- Test feature (performs display and internal tests)
- Battery operation
- Auto Shutoff and Sleep modes

Additional Model 210 Standard Features:

- Numeric keypad
- Keypad tare function
- Count feature with accumulator
- Time and Date with selectable 12 or 24 hour operation
- Checkweighing
- Three Preset Weight Comparators

Optional Features:

- Analog Output
- Battery Operation
- Special Filtering
- Column Mounting available

Certifications:

This equipment is certified to comply with the requirements for a Class III/IIIL device by the

- National Conference on Weights and Measurements (Certificate No. 01-011)
- Measurement Canada (Approval No. AM-5397)
- And for a Class III device by OIML R-76 (Certificate No. DK 0199.47).



EUROPEAN DECLARATION OF CONFORMITY

Manufacturer: Cardinal Scale Manufacturing Company
PO Box 151
203 East Daugherty
Webb City, Missouri 64870 USA

Telephone No. 417 673 4631
Fax No. 417 673 5001

Product: Non-automatic Weight Indicating Instrument
Model Numbers 200, 205, 210 and 220
Serial Number EXXXYY-ZZZ
where XXX = day of year
YY = last two digits of year
ZZZ = sequential number

The undersigned hereby declares, on behalf of Cardinal Scale Manufacturing Company of Webb City, Missouri, that the above-referenced product, to which this declaration relates, is in conformity with the provisions of:

European Standard EN 45501: 1992 and equivalent International Recommendation OIML R76, edition 1992
EU Type Approval Certificate Number DK 0199.47
Report No. DANAK-195612

Council Directive 73/23/EEC (19 February, 1993) Low Voltage Directive as amended by Council Directive 93/68/EEC (22 July, 1993)

Council Directive 90/384/EEC (20 June, 1990) on the Harmonization Of the Laws of Member States relating to non-automatic weighing Systems as amended by:
Council Directive 93/68/EEC (22 July, 1993)
Report No. DANAK-195728

European Standard EN50082: 1995 for radiated emissions and European Standard EN50082-2: 1995 Class B for EMC immunity.

The Technical Construction File required by this Directive is maintained at the corporate headquarters of Cardinal Scale Manufacturing Company, 203 East Daugherty, Webb City, Missouri.

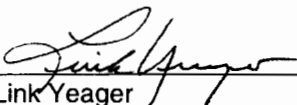
Link Yeager
Director, Quality Assurance

PRECAUTIONS

Static Electricity



CAUTION! This device contains static sensitive circuit cards and components. Improper handling of these devices or printed circuit cards can result in damage to or destruction of the component or card. Such actual and/or consequential damage IS NOT covered under warranty and is the responsibility of the device owner. Electronic components must be handled only by qualified electronic technicians who follow the guidelines listed below:



ATTENTION! ALWAYS use a properly grounded wrist strap when handling, removing or installing electronic circuit cards or components. Make certain that the wrist strap ground lead is securely attached to an adequate ground. If you are uncertain of the quality of the ground, you should consult a licensed electrician.

ALWAYS handle printed circuit card assemblies by the outermost edges. NEVER touch the components, component leads or connectors.



ALWAYS observe warning labels on static protective bags and packaging and NEVER remove the card or component from the packaging until ready for use.

ALWAYS store and transport electronic printed circuit cards and components in anti-static protective bags or packaging.

Environmental

The 205/210 indicators meet or exceeds all certification requirements within a temperature range of 14 to 104 °F (-10 to +40 °C).

In order to keep cooling requirements to a minimum, the indicator should be placed out of direct sunlight and to provide adequate air circulation, keep the area around the indicator clear.

Make certain the instrument is not directly in front of a heating or cooling vent. Such a location will subject the indicator to sudden temperature changes, which may result in unstable weight readings.

Insure that the indicator has good, clean AC power and is properly grounded.

In areas subject to lightning strikes, additional protection to minimize lightning damage, such as surge suppressors, should be installed.

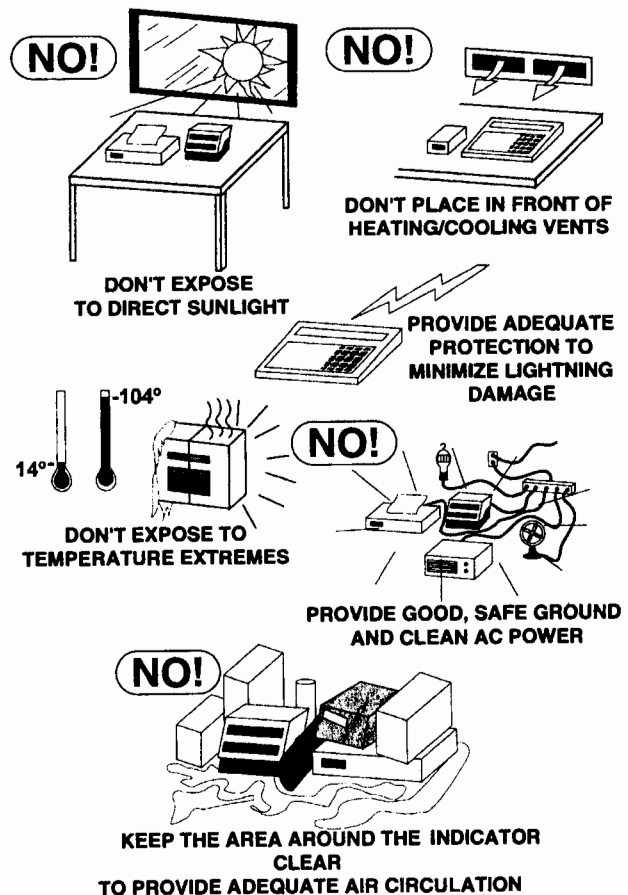

INSTALLATION

Before beginning installation of your 205/210 Weight Indicating Instrument, make certain that the instrument has been received in good condition. Carefully remove the instrument from the shipping carton and inspect it for any evidence of damage (such as exterior dents or scratches) that may have taken place during shipment. Keep the carton and packing material for return shipment if it should become necessary. It is the responsibility of the purchaser to file all claims for any damages or loss incurred during transit.

MOUNTING

NOTE! Should your 205/210 indicator come already installed on a scale, the following information describing the installation of the instrument does not apply.

The Model 205/210 Indicator is housed in a NEMA 4X/IP66 stainless steel wall or desk-mount enclosure. The 205/210 gimbal may be mounted on a desktop or other smooth, flat, horizontal surface or may be mounted on a wall. Refer to Figure No. 1 for a layout of wall-mounting bolts.

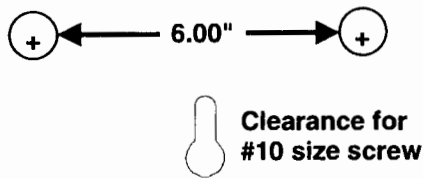
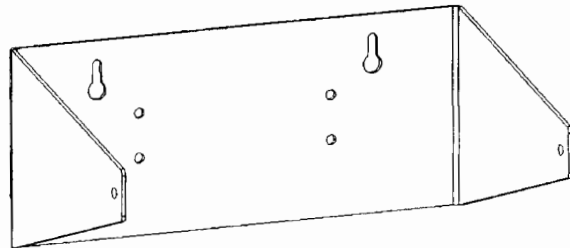

Figure No. 1



If wall mounted, make certain the mounting surface is strong enough to support the instrument. The mounting location should be where the display is easily viewed while being close enough to provide the operator easy access to the keypad. Carefully lay out the mounting hole locations, then drill and install the anchor bolts. Attach the gimbal to the wall and securely tighten the retaining bolts.

LOAD CELL CONNECTION



CAUTION! Disconnect any external load cell power supply before connecting load cells to the instrument. Failure to do so will result in permanent damage to the instrument.

1. Remove the 12 acorn nuts securing the back panel to the main housing, then loosen the bottom-left cable gland connector for the load cell. This gland connector is located on the rear panel of the enclosure. Refer to Figure No. 2 for illustration of the connector layout.
2. Slip the single cable from the load cell or load cell junction box through the gland connector and into the enclosure.
3. Remove 2" of the outer insulation jacket then remove 1/4" of insulation from each of the 4 wires and shield without sense leads or 6 wires and shield with sense leads (refer to figure No. 3).

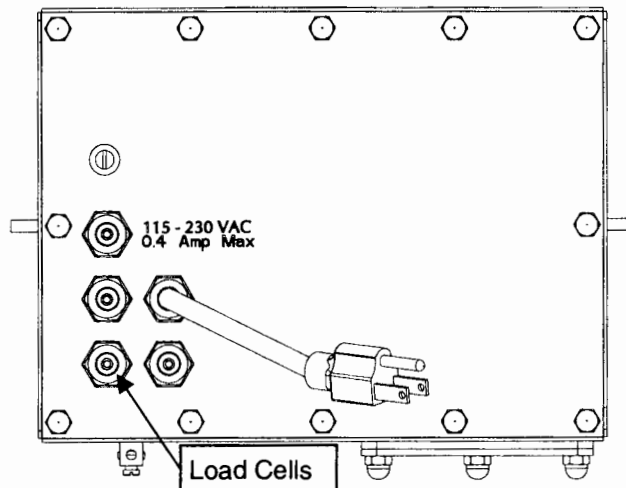

Figure No. 2

INSTALLATION, Cont.

3. Connect each of the wires to terminal block P1 referring to the labels on the circuit board for terminal connections. Refer to Figure No. 6 for terminal block location.

4. To terminate a wire, first press down on the release bar for the terminal, insert the wire into the terminal opening then allow the release bar to return to its original position, locking the wire in place. Repeat the procedure until all of the wires are in place.

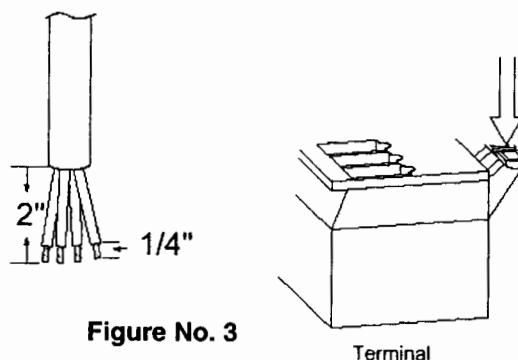

Figure No. 3

5. Route the load cell cable through the two cable clips provided on the upper and left sides of the enclosure interior.

NOTE! If the sense leads are NOT used, you must install plug-in jumpers at J4 and J5 adjacent to the terminal block. These jumpers attach the sense leads to the excitation leads. If sense leads ARE used (as in motor truck scales), these plug-in jumpers should be positioned on one plug-in pin only or removed and stored for later use (see Figure No. 6).

LOAD CELL CONNECTOR P1

<u>PIN NO.</u>	<u>Function</u>	<u>PIN NO.</u>	<u>Function</u>
1	+ EXCITATION	5	- SIGNAL
2	+ SENSE	6	- SENSE
3	+ SIGNAL	7	- EXCITATION

LOAD CELL CONNECTIONS WITH OVER 30 FEET OF CABLE

For installations with over 30 feet of cable between the indicator and the load cells, sense wires should be used. The sense wires must be connected between the +SENS, -SENS terminals on the indicator and the +EXCITATION, -EXCITATION wires of the load cells or the +SENS, -SENS terminals of the load cell trim board or the section seal trim board.

Load Cell Cable Shield Wire Connection

The load cell cable shield wire should be connected to the threaded stud inside the indicator. This stud is located on the top inside of the indicator near the load cell connector P1. See Figure No.4.

The shield wire should be wrapped around the stud between the 2 flat washers and secured using the hex nut.

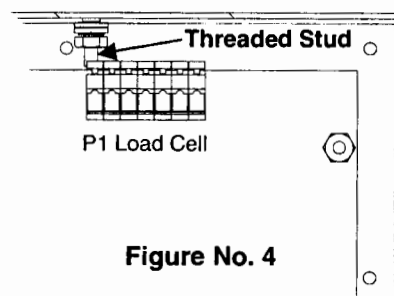

Figure No. 4

SERIAL I/O CABLE INSTALLATION

The 205/210 indicators may be connected to a printer to record weight and associated data or it may be connected to a remote display or even to a computer for transmission of weight data. The weight data may be transmitted on demand (pressing the **PRINT** key or on receipt of a command from the computer). Refer to the Setup, SIO Serial I/O section of this manual.

1. Loosen the cable gland connector(s) for the serial cable. The gland connector(s) for the serial data are located on the rear panel of the enclosure. Refer to Figure No. 2 for an illustration of the gland connector layout.
2. Slip the serial cable through the gland connector and into the enclosure.
3. Remove 2" of the outer insulation jacket then remove 1/4" of insulation from each of the wires (refer to Figure No. 3).

INSTALLATION, Cont.

SERIAL I/O CABLE INSTALLATION, Cont.

4. Connect each of the wires to the Serial Data terminal block (P11) referring to Figure No. 6 for terminal block locations.
5. To terminate, first press down on the release bar for the terminal, insert the wire into the opening then allow the release bar to return to its original position, locking the wire in place. Repeat the procedure until all of the wires are in place.

BI-DIRECTIONAL SERIAL INTERFACE

<u>PIN NO.</u>	<u>Function</u>
1	TXD 1 - RS232
2	RXD 1 - RS232
3	TXD 1 - 20 mA Active
4	GROUND

SERIAL OUTPUT

<u>PIN NO.</u>	<u>Function</u>
5	TXD 2 - RS232
6	TXD 2 - 20 mA Active
7	GROUND

OPTICALLY ISOLATED INPUTS

Included with the I/O are 4 programmable inputs that may be used to remotely (up to 100 feet) initiate various functions within the indicator. These inputs are accessed via a terminal block (P9) on the back of the PC board (see Figure No. 6). The 4 inputs are defined as follows:

<u>PIN NO.</u>	<u>Function</u>
1	Gross
2	Print
3	Zero
4	Tare
5	Common

Remember that the input must be connected to Gnd to initiate the function.

PRESET WEIGHT COMPARATOR

CHECKWEIGHER LOGIC LEVEL OUTPUT

(Optional, Model 210 Only)

If you so choose, you may use the logic level outputs from your Model 210 indicator's preset weight comparators or checkweigher to control peripheral devices used to manage the flow of material or signal when the weight is within preset limits. Note that these outputs are at logic level and cannot drive external devices directly. Solid state relays can be used to accept the logic level output from the 210 and in turn, drive the external device. Maximum output is 5VDC @ 25mA.

To connect the control cable to the preset weight comparator/checkweigher logic level output connector P10, first loosen the gland connector located on the back of the 210 on the right side. Refer to Figure No. 6 for the exact location of this connector. Slip the cable through this connector and into the enclosure. Remove 2 inches of the cable insulating jacket then 1/4 inch of insulation from each of the internal wires (refer to Figure No. 3). Make the proper terminations on terminal block P10. To terminate a wire, first press down on the terminal block release bar, insert the wire into the terminal and remove pressure from the release bar locking the wire in place.

INSTALLATION, Cont.

RELAY BOARD - (Optional, Model 210 Only)

The relay board (Cardinal p/n 8539-C062-0A) is mounted in the RB4-F external junction box for use with the 210 Indicator. Connect the devices to be controlled as shown in Figure No. 5.

The relays MUST be configured to be on (closed) or off (open) at weights under the preset weight then switch at the preset weight from on-to-off or off-to-on by setting the under weight condition to on or off during setup and calibration or setup review. Refer to the Setup and Calibration, "d out" (Digital Output) section of this manual for more information.

EXAMPLE: d oUt= 1,1

PWC1 relay is on (closed) for weights under the preset weight and off (open) for weights equal to or over the preset weight.

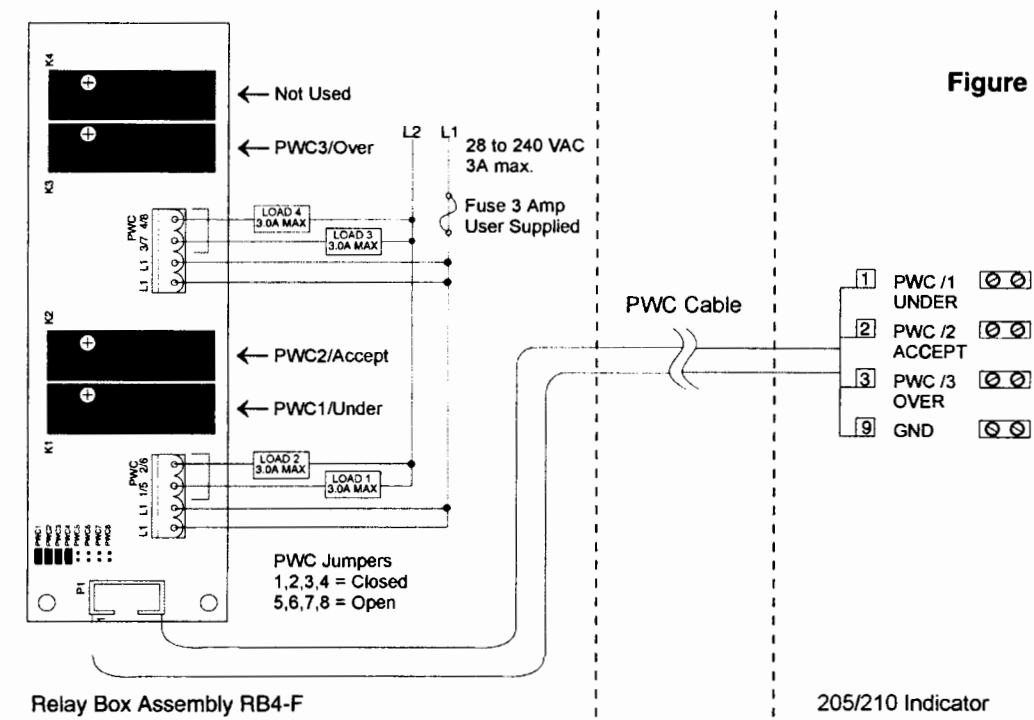

NOTE! All relays are the normally-open type that will open when power to indicator is lost.

RE-INSTALLING THE REAR PANEL

After all terminations have been made, remove the excess cable from the instrument enclosure and securely tighten each of the cable gland connectors. Do not over-tighten these connectors but make certain they are snug. **DO NOT USE TOOLS!** Finger tighten only! Insure any unused gland connectors are plugged.

Make certain no cables or wires are exposed between the main housing and rear panel then place the rear panel onto the main housing. Secure with the 12 acorn nuts removed earlier.

NOTE! Follow a diagonal pattern when tightening the acorn nuts.

INSTALLATION, Cont.

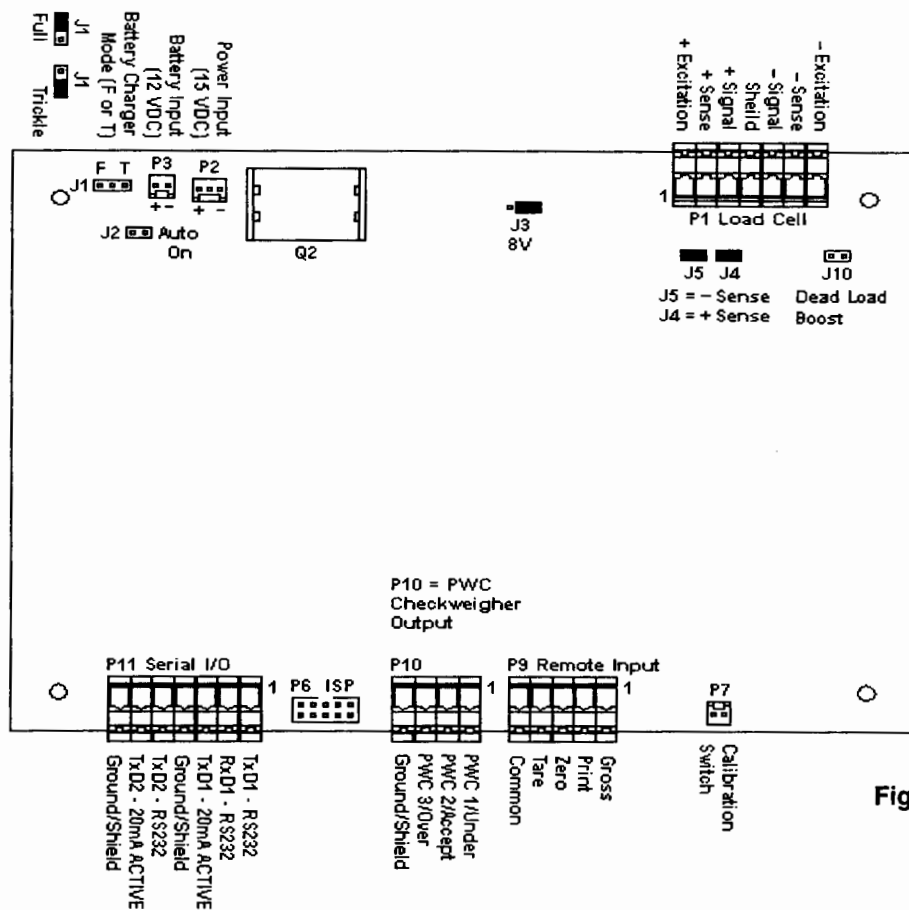

Figure No. 6

MAIN PCB JUMPERS

J1 - BATTERY CHARGE MODE

Place jumper J1 in the Full position when operating the indicator totally from battery power and only recharging the battery pack when it is low. Place jumper J1 in the Trickle position when operating the indicator from commercial power and using the battery pack to supply power only in the event of a power loss.

J2 - AUTO-ON JUMPER

The AUTO-ON jumper J2, when connected, will cause the indicator to power on automatically whenever power is applied to the power input connector. If power is lost momentarily and then reapplied, the indicator will turn on without pressing the **ON** key.

J3 - 8V EXCITATION JUMPER

The 8V EXCITATION jumper J3, when connected, sets the load cell excitation voltage to 8V for operation with the 12 VDC battery. To operate from the 12 VDC battery, the load cell excitation voltage **MUST** be set to 8 VDC (J3 *closed*). Battery operation with the load cell excitation voltage set to 12V will result in an unstable weight display.

J4 AND J5 - SENSE JUMPERS

If the sense leads are **NOT** used, you must install plug-in jumpers at J4 and J5 adjacent to the terminal block. These jumpers attach the sense leads to the excitation leads. If sense leads **ARE** used (as in motor truck scales), these plug-in jumpers should be positioned on one plug-in pin only or removed and stored for later use.

J10 - DEAD LOAD BOOST JUMPER

For very low dead loads (less than 10% of the combined load cell capacity) connect the dead load boost jumper J10 on the printed circuit board.

KEYPAD FUNCTIONS - MODEL 205

The Model 205 is equipped with a 7-key keypad. The keypad is used to enter commands and data into the instrument. This section describes each key along with its normal function. It is helpful to refer to the actual instrument while reading this section.



The membrane keypad is not to be operated with pointed objects (pencils, pens, fingernails, etc). Damage to keypad resulting from this practice is NOT covered under warranty.

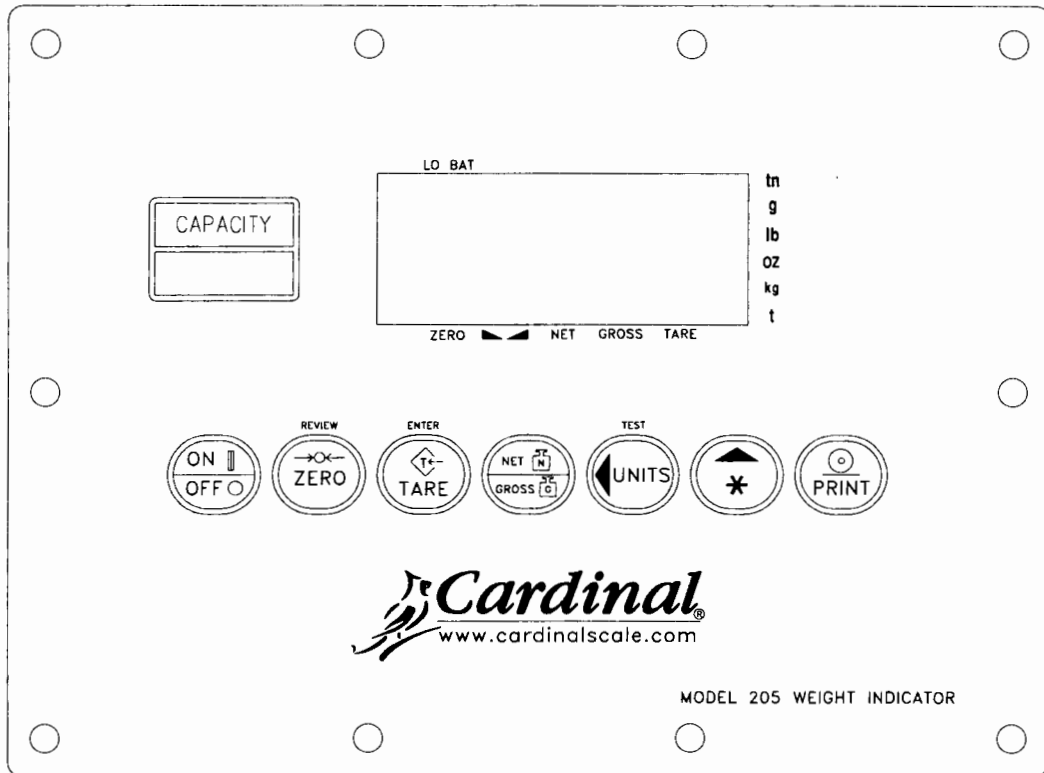

Figure No. 7

ON/OFF KEY

This key performs two functions. Pressing it when the indicator is off will apply power to the instrument. If the indicator is already on, pressing this key will turn the indicator off.

ZERO KEY

Pressing this key will cause an immediate zeroing of the weight display up to the selected limit of 4% or 100% of the scale's capacity. This selection is made during the setup and calibration of the instrument. Note the indicator will not respond to this command unless the weight display is stable.

TARE KEY

Pressing the **TARE** key alone will store the current gross weight as the new tare weight and cause the weight display to change to the net weight display mode (Net annunciator will turn on).

NET/GROSS KEY

This key is used to toggle between Net and Gross weight modes. The selected mode is indicated by turning on the appropriate annunciator on the display. Note that if no valid tare weight has been entered, pressing this key will cause a momentary "notArE" display error and the indicator will remain in the Gross weight mode.

KEYPAD FUNCTIONS - MODEL 205, Cont.

UNITS/LEFT ARROW KEY

This key performs two functions. In normal operation, this key is used to select the units in which the weight is to be displayed. The available units of measure ("unit1" and "unit2") are selected in setup. The available units include tons, pounds only, pound-ounces, ounces only, tonnes (metric tons), kilograms, and grams. Note that not all combinations are supported. During setup, this key is used to advance the cursor left to the next position when inputting setup parameters.

PRINT KEY

Pressing this key will add the displayed gross or net weight to the associated accumulator and initiate the transmission of weight and other data depending on the Print Tab Settings (see example) via the selected printer output port (see Port= under Print menu) unless the continuous data feature of this port was enabled during setup and calibration. Note that the indicator will not respond to this command unless the weight display is stable. If displaying gross weight, the only weight printed is gross weight. If displaying net weight, the gross, tare, and net weights will print.

The 205 includes support for visual tickets. Visual tickets are designed by the PC based programs Visual Print or n Control, then downloaded to the indicator. The 205 allows two programmable formats in addition to the standard print tab settings format.

Print formats are selected by using the **ASTERISK** and **PRINT** keys in combination (refer to the next section for details). **NOTE!** When the **PRINT** key is pressed the indicator looks for the selected format. If no visual ticket is found it reverts to the print tab settings.

#2
10:19 23/08/2000
100.00 lb G
20.00 lb T
80.00 lb N
0.00 lb GROSS ACCUM
272.00 lb NET ACCUM

TICKET EXAMPLE

ASTERISK/UP ARROW KEY

This key is used for several functions. During setup, when a setup parameter (not a parameter value) is displayed, pressing this key will "backup" to the previous prompt. Also during setup, when a parameter value is displayed, pressing this key will "toggle" between the different available values for the setup parameter. In normal operation, this key is used in conjunction with the other keys on the keypad to access additional indicator features. These features and their associated key combinations are as follows:

ASTERISK, ZERO KEY

This combination will enter the Review mode of Setup and Calibration. Refer to Setup Review section of this manual for details.

ASTERISK, TARE KEY

This combination will display the current tare weight for three (3) seconds.

ASTERISK, NET/GROSS KEY

This combination will display the Net accumulator.

ASTERISK, NET/GROSS KEY, PRINT KEY

This combination will print the Net accumulator.

ASTERISK, NET/GROSS KEY, ZERO KEY

This combination will zero (clear) the Net accumulator.

ASTERISK, NET/GROSS KEY, NET/GROSS KEY

This combination will display the Gross accumulator.

ASTERISK, NET/GROSS KEY, NET/GROSS KEY, PRINT KEY

This combination will print the Gross accumulator.

ASTERISK, NET/GROSS KEY, NET/GROSS KEY, ZERO KEY

This combination will zero (clear) the Gross accumulator.

KEYPAD FUNCTIONS - MODEL 205, Cont.

ASTERISK, UNITS KEY

This combination will enter the Test mode. The Test mode is used to conduct a test of all display elements. The test consists of 5 cycles, each lasting about one second:

1. All horizontal segments will turn on (no annunciators).
2. All vertical segments and decimal points will turn on (no annunciators).
3. All annunciators will turn on.
4. All display elements off.
5. The model number (205) and the software version X.X.
6. The calibration numbers (C1 to C4).

ASTERISK, PRINT KEY

This combination is used to *change* the selected print ticket format. Pressing the **ASTERISK** then the **PRINT** key will display a prompt "Prt=". Press the **ENTER** key to show the current value. If the setting displayed is acceptable, press the **ENTER** key again to save it. Otherwise, press the **ASTERISK/UP ARROW** key to "toggle" between the different available values, then press the **ENTER** key to save it. Allowable values are:

0 = print tab settings 1 = visual ticket format 1 2 = visual ticket format 2

NOTE! When a print format is selected, it will remain active until changed by the operator.

ANNUNCIATORS – MODEL 205

Annunciators are turned on to indicate that the display is in the mode corresponding to the annunciator label or that the status indicated by the label is active. The annunciators flash on and off to indicate that the 205 is waiting for an input from the keypad for the mode indicated by the flashing annunciator. Refer to Figure No. 7 for location of the annunciators.

ZERO

The ZERO annunciator indicates that the weight is within +/- 1/4 division of the center of zero.

STABLE

The STABLE annunciator is identified with two small triangle shapes and is turned on when the weight display is stable. This means that the change in successive weight samples is less than the motion limits selected during setup and calibration of the instrument.

NET

The NET annunciator is turned on to show that the displayed weight is the net weight (gross weight less tare weight).

GROSS

The GROSS annunciator indicates that the displayed weight is the gross weight.

LO BAT

The LO BAT annunciator is used with the battery operation and will turn ON to indicate that the internal battery requires charging. If continued use further drains the battery, no change in operation will occur until just before the battery voltage drops to a level where operation is affected. At this level, the indicator will automatically turn itself off. Note that when the indicator is charging the battery, the LO BAT annunciator will NOT be on.

T

The T (tons) annunciator is located to the right of the weight display and is turned on to show that the displayed weight units is tons.

g

The g (grams) annunciator is located to the right of the weight display and is used to indicate that the displayed units of weight measurement is grams.

ANNUNCIATORS - MODEL 205, Cont.

lb

The **lb** (pounds) annunciator is located to the left of the weight display and is turned on to indicate that the displayed weight units is pounds.

oz

The **oz** (ounces) annunciator is located to the right of the weight display and is turned on to show that the displayed weight units is ounces.

kg

The **kg** (kilograms) annunciator is located to the left of the weight display and indicates that the displayed units of weight measurement is kilograms.

t

The **t** (tonnes, metric tons) annunciator is located to the right of the weight display and is used to indicate that the displayed units of weight measurement is tonnes (metric tons).

KEYPAD FUNCTIONS - MODEL 210

The Model 210 is equipped with a 22-key keypad. The keypad is used to enter commands and data into the instrument. This section describes each key along with its normal function. It is helpful to refer to the actual instrument while reading this section.



The membrane keypad is not to be operated with pointed objects (pencils, pens, fingernails, etc). Damage to keypad resulting from this practice is NOT covered under warranty.

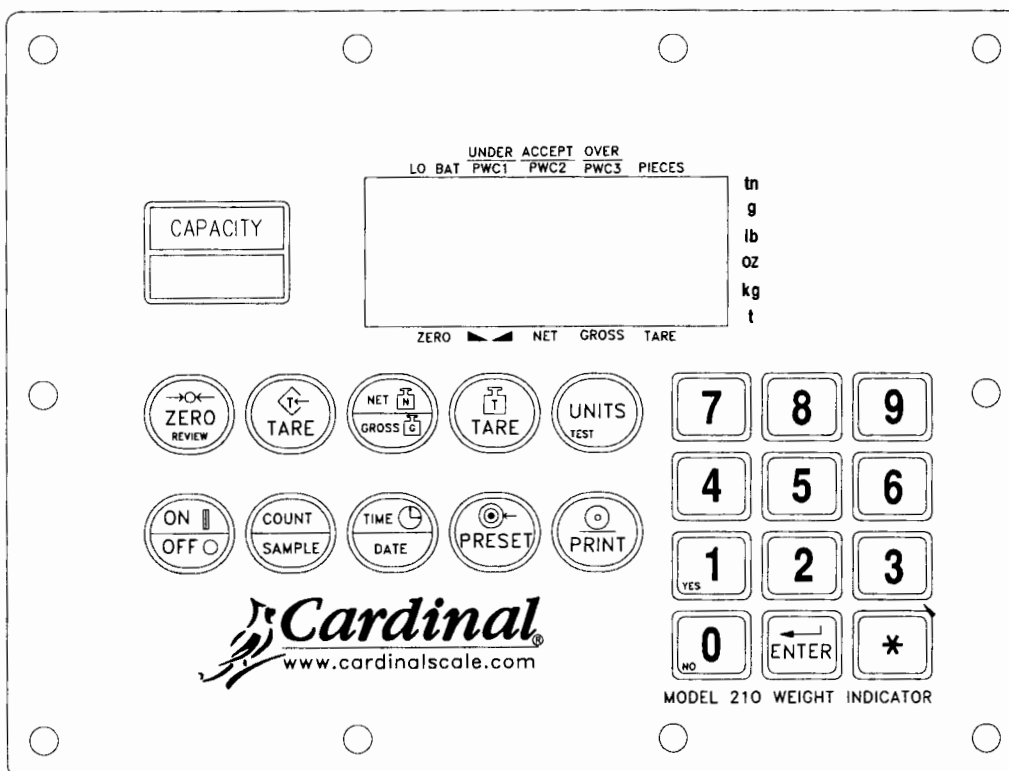

Figure No. 8

ON/OFF KEY

This key performs two functions. Pressing it when the indicator is off will apply power to the instrument. If the indicator is already on, pressing this key will turn the indicator off.

KEYPAD FUNCTIONS - MODEL 210, Cont.

COUNT/SAMPLE KEY

This key performs two functions. The first time it is pressed, the indicator will count (unless piece weight is 0). The second time it is pressed (or if pcwt=0 on the first press) will show the prompt "ADD=5" on the display. Continued pressing of the **COUNT/SAMPLE** key will toggle between the ADD=5, 10, 25, 50, 75 prompts to select a sample size. When desired sample size is displayed, press the **ENTER** key *OR* with "ADD=XX" (5, 10 etc.) displayed, using the numeric keypad, key-in any desired sample value, then press the **ENTER** key. Press the **ASTERISK** key to abort the input operation. To exit the count function and display weight, press the **NET/GROSS** key.

TIME/DATE KEY

This key is used to enter the clock mode to program the time, date and consecutive number.

Pressing the **TIME/DATE** key will enter the clock mode with the 210 displaying HoUr=.

12-Hour Format Selected In Setup (td=12)

1. With the display showing HoUr=, press the **ENTER** key.
2. If the time displayed is correct, press the **ENTER** key and proceed to step 4.
3. If the displayed time is incorrect, use the numeric keys to enter the correct time and press the **ENTER** key.
4. The display will change to A=. Press the **ENTER** key.
5. The display will show YES.
 - If the time is before noon (12:00 PM), press the **ENTER** key.
 - If the time is after noon (12:00 PM), press the **0/NO** key, then press the **ENTER** key.
6. The display will show dAtE=. Press the **ENTER** key.
7. If the date displayed is correct, press the **ENTER** key to proceed to the consecutive number prompt, Cn.C .n=.
8. If the date displayed is incorrect, use the numeric keys to enter the correct date and press the **ENTER** key to proceed to the consecutive number prompt. Remember to enter the date in the same format (month-day-year or day-month-year) as selected by the USA setup parameter. Note that with the USA=YES setting, the date format is month-day-year.

24-Hour Format Selected In Setup (td=24)

1. With the display showing HoUr=, press the **ENTER** key.
2. If the time displayed is correct, press the **ENTER** key and proceed to step 4.
3. If the displayed time is incorrect, use the numeric keys to enter the correct time and press the **ENTER** key. Note that with the 24-hour format selected, entering all times after noon (12:00 PM), you must add 12 to the time, i.e. 3 PM would be 1500.
4. The display will show dAtE=. Press the **ENTER** key.
5. If the date displayed is correct, press the **ENTER** key to proceed to the consecutive number prompt, Cn.C .n=.
6. If the date displayed is incorrect, use the numeric keys to enter the correct date and press the **ENTER** key to proceed to the consecutive number prompt. Remember to enter the date in the same format (month-day-year or day-month-year) as selected by the USA setup parameter. Note that with the USA=YES setting, the date format is month-day-year.

Consecutive Number

If the consecutive number displayed is correct, press the **ENTER** key to resume normal operation. If the consecutive number displayed is incorrect, use the numeric keys to enter the correct consecutive number (up to 6 digits) and press the **ENTER** key to resume normal operation.

KEYPAD FUNCTIONS - MODEL 210, Cont.

PRESET KEY

This key is used to enter the weight values for the three preset weight comparators or for the checkweigher feature depending on which feature was selected (setup parameter "d out") during setup and calibration.

Preset Weight Comparator

If the Preset Weight Comparator feature was selected, the PWC1 annunciator will flash and the display will show the currently stored value for the number 1 preset weight comparator. If the value displayed is acceptable, press the **ENTER** key, otherwise, use the numeric keys to enter the new preset value and press the **ENTER** key. The PWC2 annunciator will now flash and the display will show the currently stored value for the number 2 preset weight comparator. As before, if the value displayed is acceptable, press the **ENTER** key, otherwise, use the numeric keys to enter the new value and press the **ENTER** key. The PWC3 annunciator will now flash and the display will show the currently stored value for the number 3 preset weight comparator. Again, if the value displayed is acceptable, press the **ENTER** key, otherwise, use the numeric keys to enter the new value and press the **ENTER** key.

Checkweigher

If the Checkweigher feature was selected and the **PRESET** key pressed, the **ACCEPT** and **UNDER** annunciators will flash and the preset value for the minimum acceptable weight will be displayed. Press the **ENTER** key if the displayed value is correct or use the numeric keys and enter the new value and press the **ENTER** key. The **ACCEPT** and **OVER** annunciators will now flash and the display will show the minimum value of weight over the accepted range. As before, if the value shown is correct, press the **ENTER** key. If the value is incorrect, enter the new value and press the **ENTER** key to save it. Note that this value must be greater than the accept value. Remember that both the preset weight comparators and checkweigher functions operate on the absolute value of the weight ignoring the polarity. After the second preset value is entered, the 210 will return to normal operation.

PRINT KEY

Pressing this key will add the displayed gross or net weight or piece count to the associated accumulator and initiate the transmission of weight and other data selected during setup of the Print menu items via the selected printer output port (see Port= under Print menu) unless the continuous data feature of this port was enabled during setup and calibration.

Note that the indicator will not respond to the Print command unless the weight display is stable. If displaying gross weight, the only weight printed is gross weight. If displaying net weight, the gross, tare, and net weights are printed.

The 210 includes support for visual tickets. Visual tickets are designed by the PC based programs Visual Print or n Control, then downloaded to the indicator. The 210 allows two programmable formats in addition to the standard print tab settings format.

Print formats are selected by using the **ASTERISK** and **PRINT** keys in combination (refer to the next section for details). **NOTE!** When the **PRINT** key is pressed the indicator looks for the selected format. If no visual ticket is found it reverts to the print tab settings.

#2	
10:19	23/08/2000
100.00	lb G
20.00	lb T
80.00	lb N
0.00	lb GROSS ACCUM
272.00	lb NET ACCUM

TICKET EXAMPLE

ZERO/REVIEW KEY

This key performs two functions. In normal operation, pressing this key will cause an immediate zeroing of the weight display up to the selected limit of 4% or 100% of the scale's capacity. Note that this selection is made during the setup and calibration of the instrument. Pressing this key after the **ASTERISK** key will enter the Review mode of Setup and Calibration. Refer to description of **ASTERISK** key and the Setup Review section of this manual for details.

KEYPAD FUNCTIONS - MODEL 210, Cont.

TARE KEY (with diamond "T" symbol)

This key is a dual function key. Pressing the **TARE** key alone (Pushbutton Tare mode) will store the current gross weight as the new tare weight and cause the weight display to change to the net weight display mode (Net annunciator will turn on). Pressing this key after entering a numeric value (Keypad Tare) will cause the value entered to be accepted as the new tare weight.

NOTE: Tare weights equal to or greater than scale capacity cannot be entered. In addition, the keypad tare weight division value must be the same as the scale division value. For example, a unit with .005 lb as the division value will display **-Error** if you enter 1.003 for the tare weight.

NET/GROSS KEY

This key is used to toggle between Net and Gross weight modes. The selected mode is indicated by turning on the appropriate annunciator on the display. Note that if no valid tare weight has been entered, pressing this key will cause a momentary "notArE" display error and the indicator will remain in the Gross weight mode.

TARE KEY (with weight "T" symbol)

Pressing this key will display the current tare weight for three seconds.

UNITS/TEST KEY

This key performs two functions. In normal operation, this key is used to select the units in which the weight is to be displayed. The available units of measure ("unit1" and "unit2") are enabled or disabled in setup. The available units include tons, pounds only, pound-ounces, ounces only, tonnes (metric tons), kilograms, and grams. Note that not all combinations are supported. Pressing this key after the **ASTERISK** key will enter the Test mode. The Test mode is used to conduct a test of all display elements. Refer to description of **ASTERISK** key for details.

0 THROUGH 9 KEYS

These keys are used to enter numeric data during the setup and calibration as well as during normal operation of the instrument. **NOTE:** The 1 and 0 keys have dual functions. They are used to enter numeric data during setup and calibration as well as during normal operations and are also used to answer yes (1 = YES) or no (0 = NO) to various prompts.

ENTER KEY

The **ENTER** key serves two purposes. First, when reviewing setup parameters, pressing the **ENTER** key will display the current setting of the parameter. Second, the **ENTER** key is used to signal completion of the entry of data and causes the indicator to process the data entered.

ASTERISK KEY

This key is used for several functions. During Setup, when a setup parameter (not a parameter value) is displayed, pressing this key will "backup" to the previous prompt. In normal operation, this key is used in conjunction with the other keys on the keypad to access additional indicator features. These features and their associated key combinations are as follows:

ASTERISK, ZERO/REVIEW KEY

This combination will enter the Review mode of Setup and Calibration. Refer to Setup Review section of this manual for details.

ASTERISK, NET/GROSS KEY

This combination will display the Net accumulator.

ASTERISK, NET/GROSS KEY, PRINT KEY

This combination will print the Net accumulator.

ASTERISK, NET/GROSS KEY, ZERO KEY

This combination will zero (clear) the Net accumulator.

ASTERISK, NET/GROSS KEY, NET/GROSS KEY

This combination will display the Gross accumulator.

KEYPAD FUNCTIONS - MODEL 210, Cont.

ASTERISK, NET/GROSS KEY, NET/GROSS KEY, PRINT KEY

This combination will print the Gross accumulator.

ASTERISK, NET/GROSS KEY, NET/GROSS KEY, ZERO KEY

This combination will zero (clear) the Gross accumulator.

ASTERISK, UNITS KEY

This combination will enter the Test mode. The Test mode is used to conduct a test of all display elements. The test consists of five (5) cycles, each lasting about one (1) second:

1. All horizontal segments will turn on (no annunciators).
2. All vertical segments and decimal points will turn on (no annunciators).
3. All annunciators will turn on.
4. All display elements off.
5. The model number (210) and the software version X.X.
6. The calibration numbers (C1 to C4).

ASTERISK, PRINT KEY

This combination is used to *change* the selected print ticket format. Pressing the **ASTERISK** then the **PRINT** key will display a prompt "Prt=". Press the **ENTER** key to show the current value. If the setting displayed is acceptable, press the **ENTER** key again to save it. Otherwise, using the numeric keys enter the new setting, then press the **ENTER** key to save it. Allowable values are:

0 = print tab settings 1 = visual ticket format 1 2 = visual ticket format 2

In addition to using the **ASTERISK, PRINT** key combination to change the print ticket format, the operator (just prior to printing the ticket) can change the print ticket format at the end of the weighing operation. This is accomplished by performing the normal weighing operation, then pressing the desired format number (0, 1 or 2), followed by pressing the **PRINT** key.

NOTE! When a print format is selected (by either method), it will remain active until changed by the operator.

ANNUNCIATORS - MODEL 210

Annunciators are turned on to indicate that the display is in the mode corresponding to the annunciator label or that the status indicated by the label is active. The annunciators flash on and off to indicate that the 210 is waiting for an input from the keypad for the mode indicated by the flashing annunciator. Refer to Figure No. 8 for location of the annunciators.

ZERO

The ZERO annunciator is turned on to indicate that the weight is within +/- 1/4 division of the center of zero.

STABLE

The STABLE annunciator is identified with two (2) small triangle shapes and is turned on when the weight display is stable. This means that the change in successive weight samples is less than the motion limits selected during setup and calibration of the instrument.

NET

The NET annunciator is turned on to show that the displayed weight is the net weight (gross weight less tare weight).

GROSS

The GROSS annunciator is turned on to indicate that the displayed weight is the gross weight.

TARE

The TARE annunciator is turned on to show that the displayed weight is the tare weight.

ANNUNCIATORS - MODEL 210

LO BAT

The LO BAT annunciator is used with the battery operation and will turn ON to indicate that the battery has less than one hour useful life before recharging will be required. If continued use further drains the battery, no change in operation will occur until just before the battery voltage drops to a level where operation is affected. At this level, the indicator will automatically turn itself off. Refer to the Optional Battery Pack Operation section of this manual for more details.

UNDER/PWC1

The UNDER annunciator is used to signal that the displayed weight is less than the minimum value of acceptable weight used in the Checkweigher feature. Note that this annunciator is active only when the Checkweigher feature is enabled.

The PWC1 annunciator is turned on to indicate that the displayed weight is equal to or greater than the weight value stored as preset number 1. Note that this annunciator is active only when the Preset Weight Comparator feature has been enabled.

ACCEPT/PWC2

The ACCEPT annunciator is used to signal that the displayed weight is within the acceptable weight limits for the Checkweigher feature. That is, it is equal to or greater than the minimum acceptable weight and equal to or less than the maximum acceptable weight. Note that this annunciator is active only when the Checkweigher feature has been enabled.

The PWC2 annunciator is turned on to indicate that the displayed weight is equal to or greater than the weight value stored as preset number 2. Note that this annunciator is active only when the Preset Weight Comparator feature has been enabled.

OVER/PWC3

The OVER annunciator is used to signal that the displayed weight is equal to or greater than the minimum value of over weight used in the Checkweigher feature. Note that this annunciator is active only when the Checkweigher feature has been enabled.

The PWC3 annunciator is turned on to indicate that the displayed weight is equal to or greater than the weight value stored as preset number 3. Note that this annunciator is active only when the Preset Weight Comparator feature has been enabled.

T

The **T** (tons) annunciator is located to the right of the weight display and is turned on to show that the displayed weight units is tons.

g

The **g** (grams) annunciator is located to the right of the weight display and is used to indicate that the displayed units of weight measurement is grams.

lb

The **lb** (pounds) annunciator is located to the left of the weight display and is turned on to show that the displayed weight units is pounds.

oz

The **oz** (ounces) annunciator is located to the right of the weight display and is turned on to show that the displayed weight units is ounces.

kg

The **kg** (kilograms) annunciator is located to the left of the weight display and is used to indicate that the displayed units of weight measurement is kilograms.

t

The **t** (tonnes, metric tons) annunciator is located to the right of the weight display and is used to indicate that the displayed units of weight measurement is tonnes (metric tons).

SETUP AND CALIBRATION

Your 205/210 indicator has been thoroughly tested and calibrated before being shipped to you. If you received the indicator attached to a scale, calibration is not necessary. If the indicator is being connected to a scale for the first time or recalibration is necessary for other reasons, proceed as indicated.

The calibration switch is located on a bracket on the inside of the enclosure rear panel. You may gain access to this switch simply by removing the calibration switch access screw on the rear panel. Refer to Figure No. 9.

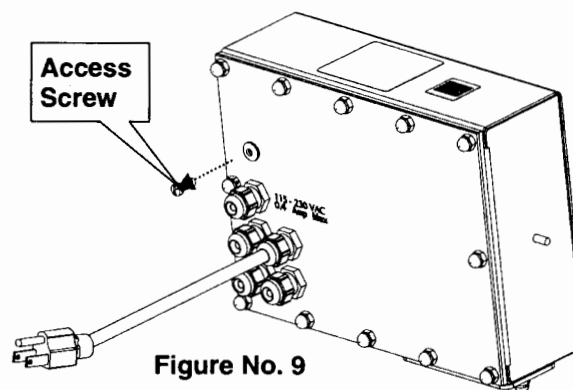

MODEL 205

During the setup and calibration process it will be necessary to enter operational parameters via the 205 keypad. Pressing the **TARE/ENTER** key (performs the same function as the **ENTER** key on the 210) will cause the data entered or displayed to be retained and the 205 to advance to the next prompt. The functions of the numeric keys are replaced by using the **UNITS/LEFT ARROW** and the **ASTERISK/UP ARROW** keys. The cursor location is identified by the blinking character and can be advanced to the left to the next position by pressing the **UNITS/LEFT ARROW** key. Pressing the **ASTERISK/UP ARROW** key will change the blinking character to the next value. Continue to press this key to "toggle" between the different available values for the setup parameter. Pressing the **ASTERISK** key when a setup parameter (not a parameter value) is displayed, will "backup" to the previous prompt.

MODEL 210

During the setup and calibration process it is necessary to enter operational parameters via the 210's keypad. Pressing the **ENTER** key without entering a new value will retain the current setting and advance the 210 to the next prompt. To change a setting, enter a new value and press the **ENTER** key. This will save the new value and advance the 210 to the next prompt. Pressing the **ASTERISK** key will "backup" to the previous prompt.



CAUTION: The membrane keypad is not to be operated with pointed objects (pencils, pens, fingernails, etc). Damage to keypad resulting from this practice will NOT be covered under warranty.

Enter Setup Mode

To enter the setup mode, with the indicator ON, insert a small screwdriver or other tool through the calibration switch access hole on the rear panel. Press and release the calibration switch. The menu SetUP will be displayed. Continue to press and release the switch to rotate through the beginning point for entering the setup mode.

SETUP	Setup Mode (starts at USA prompt)
A-d	Analog to Digital Filtering (starts at dFLt= prompt)
CAL	Calibration (starts at CAL1 prompt)
Sio	Serial Input/Output (starts at BAUD prompt)
Print	Print Tab Settings (starts at PORT prompt)
F SPAn	Fine Span Adjustment
Hi rES	Display high resolution weight mode
LoCoUt	Key lock out function
dAC	Digital to Analog Converter (If DAC board is installed, Calibration of 10 volt or 4 to 20 mA Analog Output)

If you press the **ENTER** key at the SetUP prompt, you may proceed through to the next section (up to and including fSPAn) by pressing the **ENTER** key.

SETUP AND CALIBRATION, Cont.



NOTE! Setup may be interrupted at any time. ALL data previously entered and finalized with the **ENTER** key will be retained in the non-volatile memory.

Pressing the calibration switch *at any prompt* will return you to the SETUP menu. To exit setup, press the **ASTERISK** key with any of the above menu selections displayed or cycle power at any time (press the **ON/OFF** key twice).

NOTE! With the exception of the SETUP prompt, the prompts displayed for each section are different if you push the calibration switch instead of pressing the **ENTER** key to proceed through the section. *For example*, if you press the calibration switch with the SETUP displayed, the next prompt displayed will be A-d. If you step through the setup prompts by pressing the **ENTER** key, the next prompt displayed will be A-d?. In addition, at a prompt with the ? displayed, you must press the **ENTER** key, the **1/YES** key then the **ENTER** key again to proceed with that section. To skip the section and advance you to the next menu selection, press the **ENTER** key twice.

SETUP

USA (domestic or international)

With SETUP displayed, press the **ENTER** key. The display will change to USA=. Press the **ENTER** key to show the current value. If the setting displayed is acceptable, press the **ENTER** key again to save it. Otherwise, using the numeric keys, **0/NO** or **1/YES**, enter the new setting, then press the **ENTER** key to save it.

USA = 1 (Domestic)

Date = mm/dd/yy
Trl = no
Cap + 4% to OC

USA = 0 (International)

Date = dd/mm/yy
Trl = yes
Cap + 9 grads to OC
PT printed with tare
Lamp test on power up

Lft (Legal For Trade)

Press the **ENTER** key to show the current value. If the setting displayed is acceptable, press the **ENTER** key again to save it. Otherwise, using the numeric keys, **0/NO** or **1/YES**, enter the new setting, then press the **ENTER** key to save it.

Lft = 1

Interval Settings (Int=) allowed
are: 1, 2, 5, 10, 20, 50

Lft = 0

Interval Setting (Int=) is
selectable from 1 to 99.

NOTE! When both *Lft=1 and USA=1*, the followings results occur:

Scale must have between 100 and 10,000 divisions
Tra = .5 or 0 to 3
Inhibit serial data during input
Disables **COUNT** key
Date = mm/dd/yy
Trl = no
Cap + 4% to OC

NOTE! When *Lft=1 and USA=0*, the followings results occur:

Uns = 1
Date = dd/mm/yy
Trl = yes
Cap + 9 grads to OC
PT printed with tare
Lamp test on power up

SETUP AND CALIBRATION, Cont.

Unit1= (Weighing Unit 1)

Press the **ENTER** key to show the current value. If the setting displayed is acceptable, press the **ENTER** key again to save it. Otherwise, using the numeric keys enter the new setting, then press the **ENTER** key to save it. Allowable values are:

0 = none	4 = oz (ounces)
1 = tn (tons)	5 = kg (kilograms)
2 = g (grams)	6 = tonnes (metric tons)
3 = lb (pounds)	7 = lb/oz (pounds/ounces)

Int= (Interval Setting)

Press the **ENTER** key to show the current value.

If LFt = 1 (Legal For Trade = YES), using the numeric keys enter the new setting, then press the **ENTER** key to save it. Allowable values are: 1, 2, 5, 10, 20 or 50.

If LFt=0 (Legal For Trade = NO), using the numeric keys enter the new setting, then press the **ENTER** key to save it. Allowable values are: 1 through 99.

In either case, if the setting displayed is acceptable, press the **ENTER** key again it.

dPP= (Decimal Point Setting)

Press the **ENTER** key to show the current value. If the setting displayed is acceptable, press the **ENTER** key again to save it. Otherwise, using the numeric keys enter the new setting, then press the **ENTER** key to save it. Allowable values are: 0, 1, 2 or 3.

0 = XXXXXX	2 = XXXX.XX
1 = XXXXX.X	3 = XXX.XXX

CAP= (Capacity)

Press the **ENTER** key to show the current value. If the setting displayed is acceptable, press the **ENTER** key again to save it. Otherwise, using the numeric keys enter the new setting, then press the **ENTER** key to save it. Allowable values are: 1 through 999,999.

NOTE! Capacity cannot exceed 999,999.

Unit2= (Weighing Unit 2)

Press the **ENTER** key to show the current value. If the setting displayed is acceptable, press the **ENTER** key again to save it. Otherwise, using the numeric keys enter the new setting, then press the **ENTER** key to save it. Allowable values are:

0 = none	4 = oz (ounces)
1 = tn (tons)	5 = kg (kilograms)
2 = g (grams)	6 = tonnes (metric tons)
3 = lb (pounds)	7 = lb/oz (pounds/ounces)



NOTE! The selection for Unit2 can not be the same as Unit1. In addition, dependent upon the selection for Unit1 and the interval and decimal point settings, not all unit combinations are available.

trA= (Zero Tracking Range)

Press the **ENTER** key to show the current value. If the setting displayed is acceptable, press the **ENTER** key again to save it. Otherwise, using the numeric keys enter the new setting, then press the **ENTER** key to save it. Allowable values are: 0 (disables Zero Tracking), .5, or 1 through 9.

SETUP AND CALIBRATION, Cont.

trL= (4% Zero Range)

Press the **ENTER** key to show the current value. If the setting displayed is acceptable, press the **ENTER** key again to save it. Otherwise, using the numeric keys, **0/NO** or **1/YES**, enter the new setting, then press the **ENTER** key to save it.

trL = 1 (Yes)
4% of scale capacity

trL = 0 (No)
Full capacity (no limit)

PUO= (Power-Up Zero Feature)

Press the **ENTER** key to show the current value. If the setting displayed is acceptable, press the **ENTER** key again to save it. Otherwise, using the numeric keys, **0/NO** or **1/YES**, enter the new setting, then press the **ENTER** key to save it.

PUO = 1 (Yes)
Automatic Re-Zero on Power-Up

PUO = 0 (No)
No Re-Zero on Power-Up

td= (12 or 24 Time Format) - Model 210 Only

Press the **ENTER** key to show the current value. If the setting displayed is acceptable, press the **ENTER** key again to save it. Otherwise, use the numeric keys to select the format (12 or 24 hour) of the Model 210 clock operation, then press the **ENTER** key to save it. Note that in the 24 hour format, 12 is added to all times after noon, i.e. 3 PM would be 1500.

td = 12
12 hour clock (3PM displays 3:00)

td = 24
24 hour clock (3PM displays 15:00)

d oUt= X,Y (Digital Output) - Model 210 Only

Press the **ENTER** key to show the current value. If the setting displayed is acceptable, press the **ENTER** key again to save it. Otherwise, use the numeric keys to select the X,Y values for the digital output, then press the **ENTER** key to save it.

d out= X, Y

where: X = State below cutoff (0 = LOW, 1 = High)
Y = Preset Number or Checkweigher Mode

- 0 = Digital Output is disabled
- 1 = Low State before cutoff with 1 active Preset
- 2 = Low State before cutoff with 2 active Presets
- 3 = Low State before cutoff with 3 active Presets
- 11 = High state before cutoff with 1 active Preset
- 12 = High state before cutoff with 2 active Presets
- 13 = High state before cutoff with 3 active Presets
- 4 = Low State before cutoff on Checkweigher Mode
- 14 = High state before cutoff on Checkweigher Mode

P-bAL= (Preset Print-On-Balance)

With only one Preset selected (d OUt= 1 or 11), an additional prompt P-bAL= (automatic Print on Balance) will be displayed. If selected (P-bAL=YES), when the weight equals (or is above) the preset value and all motion stops, the weight will be printed (if a printer is attached). Note, that the weight must go below 50% of the preset value before another print operation can be performed.

If the setting displayed is acceptable, press the **ENTER** key to save it. Otherwise, using the numeric keys, **0/NO** or **1/YES**, enter the new setting, then press the **ENTER** key to save it.

P-bAL = 1 (Yes)
Automatic Print on Balance
Enabled

P-bAL = 0 (No)
Automatic Print on Balance
Disabled

SETUP AND CALIBRATION, Cont.

P-bAL= (Checkweigher Print-On-Accept)

With Checkweigher selected (dOUT= 4 or 14), an additional prompt P bAL, Print on Balance, (automatic print on accept) will be displayed. If selected (P-bAL=YES), when the scale weight is stable and in the accept range of the checkweigher, the weight will be printed (if a printer is attached).

If the setting displayed is acceptable, press the **ENTER** key to save it. Otherwise, using the numeric keys, **0/NO** or **1/YES**, enter the new setting, then press the **ENTER** key to save it.

P-bAL = 1 (Yes)

Automatic Print on Accept Enabled

P-bAL = 0 (No)

Automatic Print on Accept Disabled

SLEEP= (Sleep Mode Feature)

The Sleep Mode feature conserves battery power when the indicator remains unused for a selected period of time. With the feature enabled, the load cell excitation will be reduced and the display will be blank.

Press the **ENTER** key to show the current status of this feature. If a number other than 0 is shown, this feature is selected and the number shown corresponds to the number of minutes of a stable zero weight reading before the indicator enters the sleep mode. If the setting displayed is acceptable, press the **ENTER** key again to save it. Otherwise, use the numeric keys to enter a new value (0 to 10) then press the **ENTER** key to store the new setting. Note that entry of a 0 disables this feature.

A oFF= (Auto Shutoff)

The Automatic Shutoff feature will automatically turn the indicator off (when it is not in use) after a predetermined period of inactivity to prolong battery life. To turn the instrument back on you must press the **ON / OFF** key.

Press the **ENTER** key to show the current status for this feature. A number other than 0 indicates that the auto shutoff feature is enabled and the displayed number corresponds to the number of minutes of stable weight displayed before the indicator is turned off automatically. Note that a 0 indicates the feature has been turned off. If the setting displayed is acceptable, press the **ENTER** key again to save it. Otherwise, use the numeric keys to enter a new value (0 to 10) then press the **ENTER** key to store the new setting.

CLtAr= (Clear Tare)

The Clear Tare feature allows the indicator to clear the Stored Tare weight when the Net weight goes below zero (a negative net weight after display of a positive net weight). With this feature enabled, the operator must re-set the tare after completion of a transaction when the load (container plus item) is removed from the scale.

Press the **ENTER** key to show the current value. If the setting displayed is acceptable, press the **ENTER** key again to save it. Otherwise, using the numeric keys, **0/NO** or **1/YES**, enter the new setting, then press the **ENTER** key to save it.

CLtAr = 1 (Yes)

Automatically clears Stored Tare when Net weight goes below zero

CLtAr = 0 (No)

Stored Tare is not cleared when Net weight goes below zero

The following is a typical example of the Clear Tare feature in use.

1. Place container on scale, then press **TARE** key (with diamond "T" symbol on 210).
2. Load container with item to be weighed and perform normal weighing operation.
3. Remove load (item *AND* container) from scale.
4. Scale weight returns to below zero (the weight of the container) and is then reset to zero.
5. Operator is required to repeat step 1 before next weighing operation.

SETUP AND CALIBRATION, Cont.

A - d (A - d?) - Analog to Digital Filtering

dFLt= (Digital Filtering)

With A - d (A - d?) displayed, press the **ENTER** key. The display will change to dFLt=. Press the **ENTER** key to show the current value. If the setting displayed is acceptable, press the **ENTER** key to save it. Otherwise, using the numeric keys enter the new setting, then press the **ENTER** key to save it. Allowable values are: 0, 1, 2 or 3. Note, that if you select 3 (Custom Filtering) two additional prompts will be displayed.

dFLt=	
0	Disabled – NO Filtering
1	MINIMAL FILTERING (sample rate = 2)
2	MODERATE FILTERING (sample rate = 1)
3	CUSTOM FILTERING

NOTE! The prompts, F= (Filter Level) and b= (Break Range) will only be displayed if you selected 3 (Custom Filtering) for the dFLt= (Digital Filtering) prompt.

F= (Filter Level)

Press the **ENTER** key to show the current setting for the filter level. The filter level is a number from 1 to 99 that corresponds to the level of filtering with 99 being the greatest filtering and 1 the least. To accept the value displayed, press the **ENTER** key, otherwise, use the numeric keys to enter a new value then press the **ENTER** key to save it.

b= (Break Range)

Press the **ENTER** key to show the current setting for the break range. The break range is a number from 1 to 255 that corresponds to the number of division change to break out of the filtering. Press the **ENTER** key to keep the displayed value or use the numeric keys to enter a new value and press the **ENTER** key to save the new setting. Note that entry of a 0 disables this feature.

Sr= (Sample Rate)

Press the **ENTER** key to show the current setting for the sample rate. The value displayed is the sample rate in samples per second. Press the **ENTER** key to save the displayed value or use the numeric keys to enter a new value (1 to 100) and press the **ENTER** key to save it.

UnS= (Motion Range)

Press the **ENTER** key to view the current setting for the range of motion detection. If the displayed value is acceptable, press the **ENTER** key to save it. Otherwise, use the numeric keys to enter the new range (the number of divisions of change permitted before indicating unstable), then press the **ENTER** key to save the new setting. Allowable range values are: 0 through 99 divisions.

SC= (Stable Count)

Press the **ENTER** key to view the current setting for the number of consecutive stable weight readings before indicating stable weight. This helps filter weight readings for stability for use with Auto Print on Balance, or and anything trying to capture stable weight. If the displayed value is acceptable, press the **ENTER** key to save it. Otherwise, use the numeric keys to enter a new value and press the **ENTER** key to save the new setting. Allowable values for the stable count are: 3 through 255.

SETUP AND CALIBRATION, Cont.

FILTER SETTING RECOMMENDATIONS

Non Critical Sample Rate

If the sample rate is not critical, as in static weighing, set dFLt= to "0" (no filtering), dFLt= "1" (F=6, b=12, Sr= 2/Sec), or dFLt= "2" (F=6, b=8, Sr= 1/Sec).

Critical Sample Rate

If the sample rate is critical, as in a filling operation, use the Custom Filtering (set dFLt= to "3").

1. Sr= SAMPLE RATE (1 to 50 samples/second) determination:

Set the sample rate as close as possible to produce a display graduation change for every graduation of material added to the scale.

$$\frac{\text{Material Flow Rate (lbs/second)}}{\text{Resolution}} = \text{Sr}$$

EXAMPLE: $\frac{100\text{lbs/sec}}{10\text{lbs}} = 10\text{s/s} = \text{Sr}$

2. b= BREAK RANGE (1 to 255 graduations) determination:

Turn the filtering off by setting the dFLt= setting to "0". Operate the system as it will be normally used and, by observation, determine the number of grads of instability that needs to be filtered out. Set the break range (b=) to that value.

$$\frac{\text{Weight Change}}{\text{Graduation Value}} = b$$

EXAMPLE: 20,000 x 10lb capacity scale with 800lb variation in the weight display.

$$\frac{800}{10} = b = 80$$

3. F= FILTER SETTING (1 to 99) determination: Set to desired results.
4. If stability is unacceptable with any setting of F=, reduce the sample rate and/or increase the break range, b= setting for increased filtering.

SETUP AND CALIBRATION, Cont.

CAL (CAL?) - Calibration

With CAL (CAL?) displayed, press the **ENTER** key. The display will change to show the current setting NO. If calibration is desired, press the **1/YES** key, then press the **ENTER** key to continue to the CAL1= setting, otherwise press the **ENTER** key to advance to the Sio menu.

CALIBRATION MODES

The 205/210 indicators have five modes that can be used to perform calibration. Three of the modes require a test load or test weights, one requires the scale to be empty (and at zero) and the last uses the calibration "C" numbers from a previous calibration. The modes are as follows:

1. Dual-Point with Zero (First Zero)

This is a standard calibration method requiring one weight, an empty scale and has one conversion factor. This method uses two calibration points (CAL1= and CAL2=) to establish a zero (no load) calibration value and to span the indicator. The two points correspond to zero weight and the test load or test weight and can be applied in any order. This method should be used for first-time calibration and complete recalibration.

2. Dual-Point without Zero (False Zero)

This calibration method requires one test weight and establishes a new conversion factor only. It is used to establish a false (temporary zero) zero without affecting the zero calibration value stored during the last calibration. This is particularly useful in tank weighing applications, where it may be impractical or impossible to completely empty the tank. This method uses two calibration points, CAL1= and CAL2=. The value of the test weight is entered when CAL1= is displayed and the **NET/GROSS** key is pressed when CAL2= is displayed.

3. Single-Point for Span Only (Last Zero)

This calibration method requires one test weight, the scale at zero and establishes a new conversion factor (span) without affecting the zero calibration value stored during the last calibration. This minimizes placing and removing test weights and is especially useful when checking high capacity scales. This method uses two calibration points, CAL1= and CAL2=. The value of the test weight is entered when CAL1= is displayed and the **ZERO** key is pressed when CAL2= is displayed.

4. Single-Point for Zero Only (Only Zero)

This calibration method requires no test weight, an empty scale and establishes a new zero without affecting the conversion factor (span). This is useful to regain the full range of zero limit when the dead load of the scale has changed. This would occur for example, if a guard rail has been added to the scale platform. This method uses two calibration points, CAL1= and CAL2=. The **ENTER** key is pressed when CAL1= is displayed and the **ZERO** key is pressed when CAL2= is displayed.

5. Calibration "C" Numbers

The calibration "C" numbers (C1, C2, C3 and C4) are displayed only during the Test mode operation and are shown at the end of the test. Each number is displayed for approximately 4 seconds, allowing you to record them. These numbers correspond to the calibration setting of the indicator. The numbers may be up to three digits in length. By recording these numbers you will be able to return the indicator to its present calibration settings without using test weights simply by entering the "C" numbers. *Refer to the Calibration "C" Number section of this manual for instructions on viewing the "C" numbers.*

SETUP AND CALIBRATION, CONT.

Dual-Point with Zero (First Zero) Calibration

CAL1= – FIRST CALIBRATION WEIGHT

The display will show CAL1=0. This is the first of two calibration weights. This weight could be ZERO (NO LOAD) or the TEST WEIGHTS / TEST LOAD.

- If the first calibration weight is to be ZERO (NO LOAD), press the **ENTER** key.
- If the first calibration weight is to be the TEST WEIGHTS / TEST LOAD, use the numeric keys to input the value of the calibrated test weights. **NOTE!** When entering values for CAL1=, the digits start displaying on the right side of the display and proceed to the left. When large values are used (more than 3 digits), the CAL1= prompt will automatically scroll off the left side of the display to show the additional digits on the right as they are entered.
- Place the weights on the scale platform, then press the **ENTER** key.
- Starting at the left and proceeding right, a series of dashes will appear on the display. The dashes will stay on the display momentarily, then disappear, after which the display will show: CAL2=.

CAL2= - SECOND CALIBRATION WEIGHT

The display will show CAL2=0. This is the second of two calibration weights. This weight could be ZERO (NO LOAD) or the TEST WEIGHTS / TEST LOAD.

- If the second calibration weight is to be ZERO (NO LOAD), press the **ENTER** key.
- If the second calibration weight is to be the TEST WEIGHTS / TEST LOAD, use the numeric keys to input the value of the calibrated test weights. **NOTE!** When entering values for CAL2=, the digits start displaying on the right side of the display and proceed to the left. When large values are used (more than 3 digits), the CAL2= prompt will automatically scroll off the left side of the display to show the additional digits on the right as they are entered.
- Place the weights on the scale platform, then press the **ENTER** key.
- Starting at the left and proceeding right, a series of dashes will appear on the display. The dashes will stay on the display momentarily, then disappear, after which the display will show: CAL3=.

CAL3= - LAST CALIBRATION WEIGHT

The display will show CAL3=0. This weight is not used. Press the **ENTER** key to skip CAL3= and advance to Sio?.

SETUP AND CALIBRATION, CONT.

Dual-Point without Zero (False Zero) Calibration

CAL1= – FIRST CALIBRATION WEIGHT

The display will show CAL1=0. This is the first of two calibration steps. This weight is the TEST WEIGHTS / TEST LOAD.

- Place the weights on the scale platform.
- Using the numeric keys, input the value of the calibrated test weights / test load, then press the **ENTER** key. **NOTE!** When entering values for CAL1=, the digits start displaying on the right side of the display and proceed to the left. When large values are used (more than 3 digits), the CAL1= prompt will automatically scroll off the left side of the display to show the additional digits on the right as they are entered.
- Starting at the left and proceeding right, a series of dashes will appear on the display. The dashes will stay on the display momentarily, then disappear, after which the display will show: CAL2=.

CAL2= - SECOND CALIBRATION WEIGHT

The display will show CAL2=0. This is the second of two calibration steps.

- Remove the weights on the scale platform, then press the **NET/GROSS** key.
- Starting at the left and proceeding right, a series of dashes will appear on the display. The dashes will stay on the display momentarily, then disappear, after which the display will show: Sio?.

Single-Point for Span Only (Last Zero) Calibration

CAL1= – FIRST CALIBRATION WEIGHT

The display will show CAL1=0. This is the first of two calibration steps. This weight is the TEST WEIGHTS / TEST LOAD.

- Zero the scale, then place the weights on the scale platform.
- Using the numeric keys, input the value of the calibrated test weights / test load, then press the **ENTER** key. **NOTE!** When entering values for CAL1=, the digits start displaying on the right side of the display and proceed to the left. When large values are used (more than 3 digits), the CAL1= prompt will automatically scroll off the left side of the display to show the additional digits on the right as they are entered.
- Starting at the left and proceeding right, a series of dashes will appear on the display. The dashes will stay on the display momentarily, then disappear, after which the display will show: CAL2=.

CAL2= - SECOND CALIBRATION WEIGHT

The display will show CAL2=0. This is the second of two calibration steps.

- Remove the weights on the scale platform, then press the **ZERO** key.
- The display will advance to Sio?.

SETUP AND CALIBRATION, Cont.

Single-Point for Zero Only (Only Zero) Calibration

CAL1= – FIRST CALIBRATION WEIGHT

The display will show CAL1=0. This is the first of two calibration steps.

- Insure the scale is empty.
- Press the **ENTER** key.
- Starting at the left and proceeding right, a series of dashes will appear on the display. The dashes will stay on the display momentarily, then disappear, after which the display will show: CAL2=.

CAL2= - SECOND CALIBRATION WEIGHT

The display will show CAL2=0. This is the second of two calibration steps.

- Press the **ZERO** key.
- The display will advance to Sio?.

Calibration “C” Numbers

1. With CAL1= displayed, press the "diamond T" TARE key (**UNITS** key on the 205).
2. At the C1= prompt, press the **ENTER** key to show the current value of the C1 number.
3. If the C1= number displayed is acceptable, press the **ENTER** key again to save it.
4. Otherwise, use the numeric keys to enter a new C1= number, then press the **ENTER** key.
5. Repeat steps 2 through 4 for C2=, C3= and C4=.



NOTE! If any components have been changed that affect calibration and/or your scale is used in a commercial application and must be "Legal for Trade" you cannot use the "C" numbers to re-calibrate.

SETUP AND CALIBRATION, Cont.

Sio (Sio?) - Serial Input/Output

With Sio (Sio?) displayed, press the **ENTER** key. The display will change to show the current setting "no". To skip configuring the Sio (serial input/output) and proceed to the Print? menu, press the **ENTER** key again. To configure the Sio, press the numeric key **1/YES** then the **ENTER** key. After pressing the **ENTER** key, the display will change to bAud=.

bAud= (Serial Port Baud Rate)

Press the **ENTER** key to show the current value. If the setting displayed is acceptable, press the **ENTER** key again to save it. Otherwise, use the numeric keys to enter a new baud rate for the serial ports, then press the **ENTER** key to save it. Allowable values are:

12 = 1200 Baud	24 = 2400 Baud	48 = 4800 Baud
96 = 9600 Baud	19 = 19.2k Baud	38 = 38.4k Baud
76 = 76.8k Baud		

PrtY= (Serial Port Parity)

Press the **ENTER** key to show the current value. If the setting displayed is acceptable, press the **ENTER** key again to save it. Otherwise, using the numeric keys enter the new setting, then press the **ENTER** key to save it. Allowable values are: 0, 1, or 2.

0 = NONE (No Parity)	1 = Odd Parity	2 = Even Parity
----------------------	----------------	-----------------

bitS= (Serial Port Data Bits)

Press the **ENTER** key to show the current value. If the setting displayed is acceptable, press the **ENTER** key again to save it. Otherwise, using the numeric keys enter the new setting, then press the **ENTER** key to save it. Allowable values are: 7 or 8.

StoP= (Serial Port Stop Bits)

Press the **ENTER** key to show the current value. If the setting displayed is acceptable, press the **ENTER** key again to save it. Otherwise, using the numeric keys enter the new setting, then press the **ENTER** key to save it. Allowable values are: 1 or 2.

Cont1= (Continuous Output Serial Port 1)

Press the **ENTER** key to show the current value. If the setting displayed is acceptable, press the **ENTER** key again to save it. Otherwise, using the numeric keys, **0/NO** or **1/YES**, enter the new setting, then press the **ENTER** key to save it.

Cont1= 1 (Yes) Continuous Output	Cont1= 0 (No) No Continuous Output
--------------------------------------------	----------------------------------------------

If you selected Cont1= 1 (Yes Continuous Output), an additional prompt, "tyPE=" will be displayed.

If you selected Cont1= 0 (No Continuous Output) proceed to the Weight On Demand section.

tyPE= (Continuous Output Format)

Press the **ENTER** key to show the current value. If the setting displayed is acceptable, press the **ENTER** key again to save it. Otherwise, using the numeric keys enter the new setting, then press the **ENTER** key to save it. Allowable values are: 0, 1, 2 or 3.

0 = SMA	1 = SB-400	2 = SB-200	3 = Rice Lake IQ355
---------	------------	------------	---------------------

SETUP AND CALIBRATION, Cont.

tyPE= (Continuous Output Format), Cont.

If SMA is selected, the data will be transmitted in the following format:

```
<lf><s><r><n><m><f><xxxxxx.xxx><uuu><cr>
```

Where:

lf =	Line Feed	
s =	Flags	Z= center of Zero, O = Overcap, E = zero Error, e = weight not currently being displayed
r =	Range	1, 2, 3, ...
n =	Mode	G = Gross, T = Tare, N = Net
m =	Motion	M = Motion, " " (<i>blank</i>) = no motion
f =	Custom	Custom flag
xxxxxx.xxx =	Weight	Six digits with decimal point
uuu =	Units	tn, lb, l/o, oz, t, kg, g
cr =	Carriage Return	(hex 0D)

If SB-400* or Computer is selected, the data will be transmitted in the following format:

```
<s><xxxxxx><d><uu><m><cc><cr>
```

Where:

s =	Sign	"-" = negative, " " (<i>blank</i>) = positive
xxxxxx.xxx =	Weight	Six digits
d =	Decimal point	Added to string if enabled in setup
uu =	Units	tn, lb, l/o, oz, t, kg, g
m =	Mode	G = Gross, N = Net
cc =	Weight Status	OC = overcap CZ = center of zero MO = motion ee = weight not currently being displayed
cr =	Carriage Return	(hex 0D)

*The SB-80, SB-300 (*multiple displays not supported*) and WinVRS use the SB-400 format.

If SB-200 is selected, the data will be transmitted in the following format:

```
<cr><s><xxxxxx><d><c><uu><m> ETX
```

Where:

cr =	Carriage Return	(hex 0D)
s =	Sign	"-" = negative, " " (<i>blank</i>) = positive
xxxxxx.xxx =	Weight	(with leading zeros)
d =	Decimal point	Embedded into weight (after weight dpp=0)
c =	status	m = motion o = overcap e = weight not currently being displayed
uu =	Units	tn, lb, l/o, oz, t, kg, g
m =	Mode	G = Gross, N = Net
ETX =	End of TeXt	(hex 03) MUST terminate ALL serial commands

SETUP AND CALIBRATION, Cont.

tyPE= (Continuous Output Format), Cont.

If Rice Lake IQ355 is selected, the data will be transmitted in the following format:

```
<stx><polarity><wwwwwww><units><g/n><status><crlf>
```

Where:

stx =	Start of TeXt	(hex 02)
polarity =	Sign	"-" = negative, " " (<i>blank</i>) = positive
wwwwwww =	Weight	Seven digits
units =	Units	" " (<i>blank</i>) = none, L = lb, K = kg, T = tons, G = grams, O = ounces
g/n	Mode	G = Gross, N = Net
status	status	" " (<i>blank</i>) = valid I = invalid M = motion O = overcap
CRLF =	Carriage Return with Line Feed	(hex 0D) with (hex 0A)

Weight On Demand

If continuous output has not been selected for Serial Port 1 (Cont1=NO), the 205/210 indicator will respond to a weight request (ENQ).

The host device (computer) sends:

ENQ - (hex 05)

The 205/210 will respond:

```
<s><xxxxxx><d><uu><m><cc><cr>
```

Where:

s =	Sign	"-" = negative, " " (<i>blank</i>) = positive
xxxxxx.xxx =	Weight	Six digits
d =	Decimal point	Added to string if enabled in setup
uu =	Units	tn, lb, l/o, oz, t, kg, g
m =	Mode	G = Gross, N = Net
cc =	Weight Status	OC = overcap CZ = center of zero MO = motion ee = weight not currently being displayed
cr =	Carriage Return	(hex 0D)

NOTE! The Weight On Demand function is not available for Serial Port 2.

SETUP AND CALIBRATION, Cont.

Cont2= (Continuous Output Serial Port 2)

Press the **ENTER** key to show the current value. If the setting displayed is acceptable, press the **ENTER** key again to save it. Otherwise, using the numeric keys, **0/NO** or **1/YES**, enter the new setting, then press the **ENTER** key to save it.

Cont2= 1 (Yes)
Continuous Output

Cont2= 0 (No)
No Continuous Output

If you selected Cont2= Yes (Continuous Output) an additional prompt, "tyPE=" will be displayed.

tyPE= (Continuous Output Format)

Press the **ENTER** key to show the current value. If the setting displayed is acceptable, press the **ENTER** key again to save it. Otherwise, using the numeric keys enter the new setting, then press the **ENTER** key to save it. Allowable values are: 0, 1, 2 or 3.

0 = SMA 1 = SB-400 2 = SB-200 3 = Rice Lake IQ355

NOTE! See Continuous Output Serial Port 1, tyPE= for description of output formats.

Print (Print?) - Print Tab Settings

With Print (Print?) displayed, press the **ENTER** key. The display will change to show the current setting "no". To skip configuring the Print Tab Settings and proceed to the FSPAN? menu, press the **ENTER** key again. To configure the Print Tab Settings, press the numeric key **1/YES** then the **ENTER** key. After pressing the **ENTER** key the display will change to Port=.

The general format for the input is A = YY.XX where A is the character identifying the data printed, YY is the number of lines down and XX is the number of spaces to the right.



NOTE! Enter 00 in either location, YY or XX, to disable the data from printing.

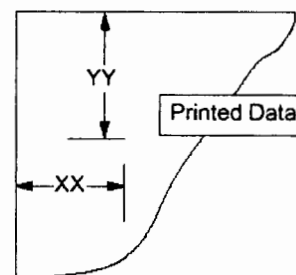

Port= (Select Port for Printer)

Press the **ENTER** key to show the current value. If the setting displayed is acceptable, press the **ENTER** key again to save it. Otherwise, using the numeric keys enter the new setting, then press the **ENTER** key to save it. Allowable values are: 1 or 2.



NOTE! Although either port can be used for the printer port, it is recommended to use the bi-directional port 1 with a bi-directional cable.

HoUr= (Time Print Location)

Press the **ENTER** key to show the current setting for the location of the time printing. If the setting displayed is acceptable, press the **ENTER** key again to save it. Otherwise, use the numeric keys to enter the new location then press **ENTER** to save it.

dAtE= (Date Print Location)

Press the **ENTER** key to show the current setting for the location of the date printing. If the setting displayed is acceptable, press the **ENTER** key again to save it. Otherwise, use the numeric keys to enter the new location then press **ENTER** to save it.

SETUP AND CALIBRATION, Cont.

CnC n= (Consecutive Number Print Location)

Press the **ENTER** key to show the current setting for the location of the consecutive number printing. If the setting displayed is acceptable, press the **ENTER** key again to save it. Otherwise, use the numeric keys to enter the new location then press **ENTER** to save it.

GroSS= (Gross Weight Print Location)

Press the **ENTER** key to show the current setting for the location of the Gross weight printing. If the setting displayed is acceptable, press the **ENTER** key again to save it. Otherwise, use the numeric keys to enter the new location then press **ENTER** to save it.

tArE= (Tare Weight Print Location)

Press the **ENTER** key to show the current setting for the location of the Tare weight printing. If the setting displayed is acceptable, press the **ENTER** key again to save it. Otherwise, use the numeric keys to enter the new location then press **ENTER** to save it.

nEt= (Net Weight Print Location)

Press the **ENTER** key to show the current setting for the location of the Net weight printing. If the setting displayed is acceptable, press the **ENTER** key again to save it. Otherwise, use the numeric keys to enter the new location then press **ENTER** to save it.

G ACC= (Gross Weight Accumulator Print Location)

Press the **ENTER** key to show the current setting for the location of the Gross weight accumulator printing. If the setting displayed is acceptable, press the **ENTER** key again to save it. Otherwise, use the numeric keys to enter the new location then press **ENTER** to save it.

n ACC= (Net Weight Accumulator Print Location)

Press the **ENTER** key to show the current setting for the location of the Net weight accumulator printing. If the setting displayed is acceptable, press the **ENTER** key again to save it. Otherwise, use the numeric keys to enter the new location then press **ENTER** to save it.

CoUnt= (Count "number of pieces on the scale" Print Location) - Model 210 Only

Press the **ENTER** key to show the current setting for the location of the Count (number of pieces on the scale) printing. If the setting displayed is acceptable, press the **ENTER** key again to save it. Otherwise, use the numeric keys to enter the new location then press **ENTER** to save it.

EACH= (Piece Weight Print Location) - Model 210 Only

Press the **ENTER** key to show the current setting for the location of the Piece weight printing. If the setting displayed is acceptable, press the **ENTER** key again to save it. Otherwise, use the numeric keys to enter the new location then press **ENTER** to save it.

CrLF= (Carriage Return Line Feed) - Data Format Termination

Data transmitted from the serial I/O port can be terminated with a single carriage return and either no line feed or a single line feed command. Press the **ENTER** key to view the current setting. A "YES" on the display means the data will be terminated with a carriage return AND a line feed while a "no" on the display means the data will be terminated with a single carriage return only.

If the setting displayed is acceptable, press the **ENTER** key again to save it. Otherwise, using the numeric keys, **0/NO** or **1/YES**, enter the new setting, then press the **ENTER** key to save it.

SETUP AND CALIBRATION, Cont.

EoP= (End-Of-Print Line Feeds)

At the end of a data transmission to a printer, the indicator can transmit a pre-selected number of line feed commands to space the paper in the printer to the desired position for withdrawal or for the next print.

Press the **ENTER** key to view the current setting. If the displayed value is acceptable, press the **ENTER** key to save it. Otherwise, use the numeric keys to enter the new the number of End-Of-Print linefeeds, then press the **ENTER** key to save the new setting. Allowable values are: 0 through 99.



NOTE! The FSPAN and Hi rES modes require a load of 10% of Capacity be on the scale before adjustments can be made.

F SPAn (FSPAN?) - Fine Span Adjustment

*With the F SPAn? prompt displayed after pressing the **ENTER** key at the last Print prompt:*

With FSPAN? displayed, press the **ENTER** key. The display will change to show the current setting "no". To skip the Fine Span Adjustment and return to the SETUP menu, press the **ENTER** key again. To perform the Fine Span Adjustment, place a calibrated test weight on the scale and press the numeric key **1/YES** then the **ENTER** key.

After pressing the **ENTER** key, the display will change to show the amount of the test weight and the annunciators will alternately flash off and on i.e. (all ON, weighing unit off, then all OFF, weighing unit ON). Press the **1/YES** to increase the span *OR* press the **0/NO** key to decrease the span. Press the **ASTERISK** key to return to the previous prompt or press the **ENTER** key to exit FSPAN? and return to the SetUP menu.

With the F SPAn prompt displayed after pressing the Calibration switch:

With F SPAn displayed, place a calibrated test weight on the scale and press the **ENTER** key. After pressing the **ENTER** key, the display will change to show the amount of the test weight and the annunciators will alternately flash off and on (all ON, weighing unit off, then all OFF, weighing unit ON). Press the **1/YES** to increase the span *OR* press the **0/NO** key to decrease the span. Press the **ASTERISK** key to return to the previous prompt or press the **ENTER** key to exit F SPAn and return to the SETUP menu.

Hi rES - Display High Resolution Weight

With Hi rES on the display, pressing the **ENTER** key will show the active weight in "high resolution" mode (in 1/10 interval). Press the **PRINT** key to print the weight (followed by the text TEST) via the selected printer output port enabled during setup and calibration.

LoCoUt - Key Lock Out Function

With LoCoUt on the display, pressing *any* key will display "LoCd" (locked) or "UnLoCd" (unlocked) for the current key state. Pressing a locked key during normal operation will results in a 1/2 second display "LoCd" and the key will be ignored. To exit the LoCoUt function, press the calibration switch or cycle power (press the **ON/OFF** key twice).



NOTE! The menu selections Hi rES and LoCoUt can only be selected using the calibration switch.

SETUP REVIEW

The 205/210 indicators allow several operational parameters to be reviewed and changed without breaking the calibration seal. These operational parameters are:

Power Up Zero Reset Enable/Disable
Time Format
Digital Output Control Enable/Disable
Sleep Mode Feature Enable/Disable
Auto Shutoff Feature Enable/Disable
Serial Input / Output Configuration
 Baud Rate
 Parity
 Number of Data Bits
 Number of Stop Bits
 Continuous Output Port 1
 Continuous Output Format
 Continuous Output Port 2
 Continuous Output Format

Print Tab Settings
 Printer Port Selection
 Time
 Date
 Consecutive Number
 Gross Weight
 Tare Weight
 Net Weight
 Gross Weight Accumulator
 Net Weight Accumulator
 Count (*Model 210 Only*)
 Piece Weight (*Model 210 Only*)

To enable the Setup Review feature, with the indicator ON:

1. Press the **ASTERISK** key. The indicator will respond by showing the FunCt= (Function) prompt and alternately flashing off and on (all ON, weighing unit off, then all OFF, weighing unit ON) the annunciators.
2. Press the **ZERO/REVIEW** key. The display will change to the prompt for the selection of power-up zeroing (PUO=).
3. Using the same procedure as described in the Setup and Calibration section of this manual, make the required changes.
4. Press the **ASTERISK** key to return to the previous prompt.
5. To exit Setup Review, press the **ENTER** key to step the remaining prompts *OR* at anytime, cycle the power (press the **ON/OFF** key twice).

CALIBRATION "C" NUMBERS

The "C" numbers are displayed only during the Test mode operation by pressing the **ASTERISK** key then the **UNITS/TEST** key. The "C" numbers are shown at the end of the test operation and each number is displayed for approximately 4 seconds, allowing you to record them. Each number may be up to three (3) digits in length. By recording these numbers you will be able to return the indicator to its present calibration settings without using test weights simply by entering the "C" numbers. *Refer to the Setup and Calibration, "CAL" section of this manual for instructions on using the "C" numbers.*



If any components have been changed that affect calibration and/or your scale is used in a commercial application and must be "Legal for Trade" you can not use "C" numbers to re-calibrate.

ACCUMULATORS

To view the NET accumulator:

1. Press the **ASTERISK** key then the **NET/GROSS** key.
2. Press the **ASTERISK** key to return to normal operation.

To print the NET accumulator:

1. Press the **ASTERISK** key, the **NET/GROSS** key, then the **PRINT** key
2. The indicator will return to normal operation when printing has been completed.

To clear (zero) the NET accumulator:

1. Press the **ASTERISK** key, the **NET/GROSS** key, then the **ZERO** key
2. Press the **ASTERISK** key to return to normal operation.

To view the Gross accumulator:

1. Press the **ASTERISK** key then the **NET/GROSS** key twice.
2. Press the **ASTERISK** key to return to normal operation.

To print the Gross accumulator:

1. Press the **ASTERISK** key, the **NET/GROSS** key twice, then the **PRINT** key
2. The indicator will return to normal operation when printing has been completed.

To clear (zero) the Gross accumulator:

1. Press the **ASTERISK** key, the **NET/GROSS** key twice, then the **ZERO** key
2. Press the **ASTERISK** key to return to normal operation.

MODEL 210 Only

To view the Count accumulator:

1. Press the **ASTERISK** key then the **COUNT/SAMPLE** key.
2. Press the **ASTERISK** key to return to normal operation.

To print the Count accumulator:

1. Press the **ASTERISK** key, the **COUNT/SAMPLE** key, then the **PRINT** key
2. The indicator will return to normal operation when printing has been completed.

To clear (zero) the Count accumulator:

1. Press the **ASTERISK** key, the **COUNT/SAMPLE** key, then the **ZERO** key
2. Press the **ASTERISK** key to return to normal operation.

BEFORE YOU CALL FOR SERVICE

The 205/210 indicators have been designed to provide you with years of trouble-free operation. However, should you experience a problem, please refer to the troubleshooting guide below before you call for service. The following describes several types of symptoms along with suggested remedies.

PROBLEM	POSSIBLE SOLUTIONS
Display does not turn on	<p>AC operation: Is the AC power cord fully inserted into the wall receptacle? Check wall receptacle for proper AC power. Try another electrical appliance in the same receptacle, does it work? Check the circuit breaker. Has there been power failure?</p> <p>Battery operation: Check if battery is installed and correctly. Is battery discharged - replace or recharge.</p>
Incorrect weight displayed	<p>Has the instrument been calibrated? Insure that the scale platform isn't touching an adjacent object. Check the load cell connector wiring. If using four (4) wire load cells, insure the sense lead jumpers (J4 & J5) are installed. Have proper operation procedures been followed?</p>
Indicator will not display weight	<p>Refer to Error Codes section and make certain that the "oCAP" message is not displayed. If so, and scale is not loaded, perform the calibration sequence.</p>
The printer prints but does not use the Print Tab Settings or prints a test ticket	<p>The print tab setting or visual ticket format must be selected prior to beginning the weighing operation or just prior to printing the ticket.</p> <p>To select the ticket format prior to beginning the weighing operation:</p> <ol style="list-style-type: none">1. Press the ASTERISK key then the PRINT key. The display will change to the "Prt=".2. Press the ENTER key to show the current value.3. If the value displayed is acceptable, press the ENTER key again to save it.4. If the displayed value is incorrect (or another ticket format is desired), use the numeric keys to enter the new value, then press the ENTER key to save it. <p>To select the ticket format just prior to printing the ticket:</p> <ol style="list-style-type: none">1. Press the desired format number.2. Pressing the PRINT key. <p>Allowable values for ticket formats are:</p> <ul style="list-style-type: none">0 = print tab settings1 = visual ticket format 12 = visual ticket format 2 <p>NOTE! When a print format is selected (by either method), it will remain active until changed by the operator.</p>

ERROR CODES

The 205/210 indicators are equipped with software that indicates when an error in the operation takes place. The following lists the error codes displayed by the 205/210 along with their meaning. Should you encounter an error code, please refer to this list for the cause.

CALbtn (Calibration Button)

CALbtn will be displayed (until the condition changes), on power-up if the calibration switch is pressed in by the operator, the calibration access screw is the wrong length and is depressing the switch, the switch is disconnected from the PC board, or the switch is defective.

CORRECTIVE ACTION: Release the switch. Insure correct screw (#10 x ½ Stainless Steel fillister head) was installed for the calibration access screw. Referring to Figure No. 6, make sure calibration switch cable is plugged into P7 on the PC board. Replace calibration switch assembly. Consult your scale service provider.

ConFiG (Configuration)

E²PROM checksum failure. Indicates improper stored calibration data, calibration is necessary.

CORRECTIVE ACTION: Recalibrate with calibrated test weight.

Error

An invalid keypad entry was attempted:

- A. **PRINT** key pressed with a negative weight.
- B. **TARE** key pressed to enter a push button tare value of a negative value.
- C. **ENTER** key pressed to enter a tare weight value that exceeds the scale capacity.
- D. **ENTER** key pressed to enter a tare weight value that is inconsistent with the scale division value (i.e. attempt to enter a tare of 123 with scale divisions of 5).
- E. **ZERO** key pressed when the gross weight is outside the scale zero weight range.
- F. **lb/kg** key pressed to change to kg when the kg tare weight value exceeds 4 digits in length.

CORRECTIVE ACTION: Determine which of the reasons for the error display is applicable and take the appropriate corrective action.

ErrAh (Analog Error High)

1. The load cell input is above the range of the indicator.

CORRECTIVE ACTION: Check for improper load cell wiring, excessive load, and for output of 1 to 40mV.

2. Load cell or circuit failure.

CORRECTIVE ACTION: Consult your scale service provider.

ErrAL (Analog Error Low)

1. The load cell input is below the range of the indicator.

CORRECTIVE ACTION: Check for improper load cell wiring and for output of 1 to 40mV.

2. Load cell or circuit failure.

CORRECTIVE ACTION: Consult your scale service provider.

Err1

A program checksum mismatch has been detected.

CORRECTIVE ACTION: Consult your scale service provider.

Err3

Internal RAM failure.

CORRECTIVE ACTION: Consult your scale service provider.

HuH?

UNITS key pressed in an attempt to perform a "unit" conversion that is not allowed.

CORRECTIVE ACTION: Determine the reason for the error display and take the appropriate corrective action.

ERROR CODES, Cont.

notArE

NET key pressed with no stored tare weight value.

CORRECTIVE ACTION: Determine the reason for the error display and take the appropriate corrective action.

OCAP (Over Capacity)

The load on the scale exceeds the scale capacity plus nine (9) divisions.

CORRECTIVE ACTION: Remove the over capacity load from the scale platform. May indicate miscalibration.

-oF- (Overflow)

The indicator is attempting to display a positive number greater than six (6) digits in length or a negative number of more than five (5) digits.

CORRECTIVE ACTION: Return to Gross Weight mode and review Tare value. May indicate miscalibration.

toobiG

UNITS key pressed in an attempt to perform a "unit" conversion where the interval would have been greater than 50.

CORRECTIVE ACTION: Determine the reason for the error display and take the appropriate corrective action.

UnStb (Unstable)

Motion is present when trying to power up, print, zero or perform a push button tare function.

CORRECTIVE ACTION: Wait for a stable weight display (*STABLE* annunciator on) before performing any of these operations.

CALIBRATION SEAL INSTALLATION

If your 205/210 Weight Indicating Instrument is used in a commercial application it must be tested and sealed by your local weights and measurements official. The 205/210 is designed to accept a lead and wire security seal to prevent unauthorized access to the calibration adjustments. Refer to Figure No. 10 for details on the installation of the seal.

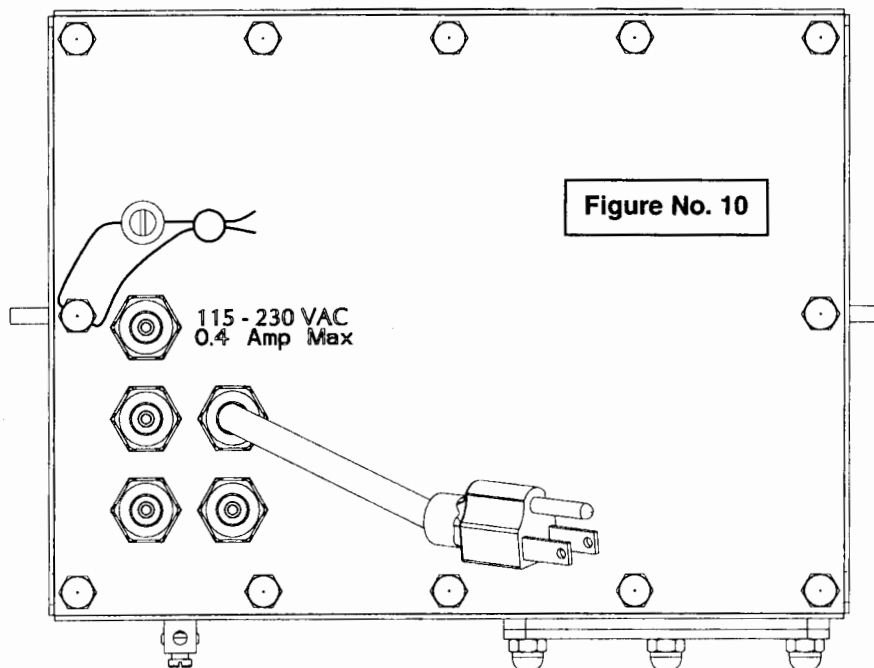

OPTIONAL BATTERY OPERATION

The 205/210 indicators can operate from a Sealed Lead-Acid Camcorder type battery (*not included*). If you wish to operate the indicator from a battery, you must first obtain and install a CAM-350 Type, 12 volt, 2000 mAh (2.0 Ah) battery before operation can begin. The battery is contained inside the instrument and is easy to install. Access is via a removable panel on the bottom of the indicator (See Figure No. 11). The battery can be purchased from the Cardinal Scale Parts Department (p/n 6800-0018).

The battery life of the indicator varies significantly with the way the indicator is used (e.g. the longer more display segments are on, the faster the battery will discharge). The battery used in the 205/210 indicator will power it continuously, with four 350 ohm load cells, for from 5.5 hours (with maximum display segments on) to 9 hours (with minimum display segments on). This time can be extended if the Sleep and Auto-Shutoff features are employed.

LOAD CELLS	BATTERY LIFE (in Hours)
1	7 to 13
2	6.5 to 11.5
3	6 to 10
4	5.5 to 9
6	5 to 7.5
8	4.5 to 6.5



NOTE! The 205/210 indicators are shipped with the load cell excitation voltage set to 12V (J3 *open*). To operate from a 12 VDC battery, the load cell excitation voltage **MUST** be set to 8V (J3 *closed*). Battery operation with the load cell excitation voltage set to 12V will result in an unstable weight display. Refer to Figure No. 6 for location of J3.

Battery Installation

1. Remove the AC power to the indicator.
2. Referring to Figure No. 11, remove the three acorn nuts securing the Battery Access Cover to the bottom of the indicator, then remove the cover exposing the battery access opening.
3. Insure the (-) negative polarity markings of the battery are positioned facing up (towards the front of the indicator) and the alignment notch in the battery is to the left.
4. Slide the battery into the opening, compressing the battery ejector spring, until you feel resistance and the battery is almost flush with the bottom of the indicator.
5. Replace the Battery Access Cover and install the three acorn nuts removed earlier, securing the battery in place.

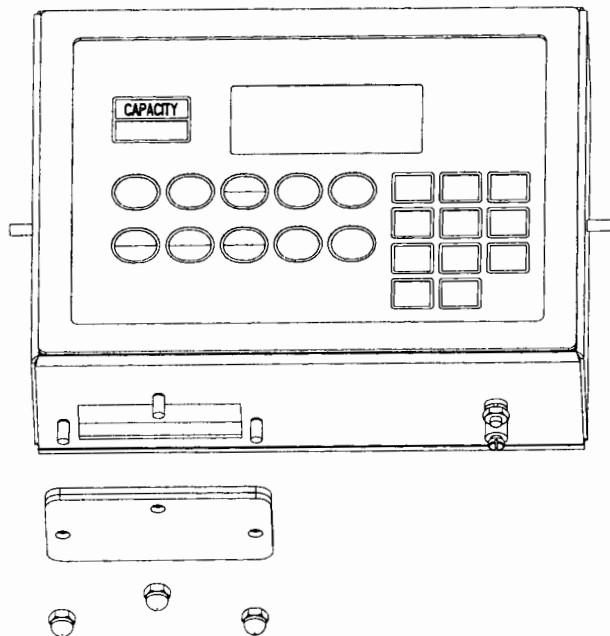

Figure No. 11

OPTIONAL BATTERY OPERATION, Cont.

Battery Removal

1. Remove the AC power to the indicator.
2. Referring to Figure No. 11, remove the three acorn nuts securing the Battery Access Cover to the bottom of the indicator.
3. Remove the cover, exposing the battery access opening.
4. An internal spring will push the battery partially out of the opening. Grasp the end of the battery and slide it out of the opening.
5. Replace the Battery Access Cover and install the three acorn nuts remove earlier.

Discharging the Battery

The battery is discharging when the indicator is operated without the AC power cord plugged into a wall outlet. The LO BAT annunciator on the indicator keypad serves to indicate the state of the battery. When the indicator is operating by battery power, and the battery has sufficient charge to power the indicator, the LO BAT annunciator is off. If the battery becomes discharged while the indicator is in use, the LO BAT annunciator will turn ON to indicate the battery needs to be charged. When this occurs, the battery will have sufficient charge to power the indicator for a short time (less than 1 hour of operation) before recharging is required.

If continued use further drains the battery to a level where the battery is unable to adequately power the indicator, the indicator will turn off automatically to prevent damaging the battery.

NOTE! If the battery has become severely discharged, the indicator may not respond at all when turned on. This is a safety feature to prevent the indicator from being powered up when the battery voltage is excessively low. Plug the indicator into the AC wall outlet to charge the battery.



Due to the nature of batteries, shutting the indicator OFF will cause the battery to recover slightly. If the indicator is operated after turning itself off, it may run for a few minutes before the LO BAT annunciator turns ON again. If the battery is too discharged to power the indicator, it will automatically turn itself off when the **ON/OFF** key is pressed.

Charging the Battery

The battery can be recharged with the indicator's built-in charger. Note that the battery can be left connected to the charger indefinitely, without risk of damage.

Cyclic Operation

When operating the indicator totally from battery power and only recharging when the batteries are low, place the Battery Charge Mode jumper(J1) in the FULL position. For the location of the Battery Charge Mode jumper(J1), refer to Figure No. 6.

Back-Up Operation

When operating the indicator from commercial power and using the battery to supply power only in the event of a power loss, place the Battery Charge Mode jumper(J1) in the TRICKLE position. For the location of the Battery Charge Mode jumper(J1), refer to Figure No. 6.

When the battery installed in a indicator needs to be charged, simply plug the AC power cord into a wall outlet and charging will begin. Note that operating the indicator during charging only minimally affects the charge time of the battery. The indicator can operate at a 100% duty cycle and will only prolong the charge time by less than 20%. Note too that charge time is dependent on the depth of the discharge and will vary from one application to the next, but will typically not exceed 10 hours even with the indicator turned on.



NOTE! While the 12 VDC battery is charging, the LO BAT annunciator will remain ON until the battery is charged to approximately 10 volts. Upon reaching that level, the LO BAT annunciator will turn off. This DOES NOT mean the battery is fully charged, only that the battery has reached a charge sufficient to turn off the LO BAT annunciator. At the level of charge where the LO BAT annunciator turns OFF, without further charging, the indicator will only operate for a few minutes before turning ON the LO BAT annunciator again, indicating additional charging is required.

OPTIONAL BATTERY OPERATION, Cont.

Optimum Battery Performance

The life of the battery depends greatly on the duty cycle of the indicator, depth of discharge and operating temperature. The battery will normally provide 10 hours of continuous operation within an operating range of 14 to 104 °F (-10 to +40 °C). Several steps can be taken to optimize the performance and life of the battery.

1. Enable the Auto Shut-Off feature. This feature will cause the indicator to shut itself off after the period of inactivity selected in setup, thus preserving the battery. (Refer to the Setup and Calibration section for an explanation of the Auto Shut-Off feature).
2. If possible, plug the AC power cord into a wall outlet after each work shift to allow the battery to recharge. This will minimize the depth of discharge and greatly increase the number of cycles the battery can undergo.
3. If conditions permit, avoid charging and discharging the battery in extreme cold. Due to the chemistry of batteries, low temperatures decrease the capacity of the battery significantly causing a greater depth of discharge at colder temperatures than at room temperature. The battery will function without problems at temperatures as low as 14 °F (-10 °C) but will not last as many cycles as it would at room temperature.
4. Avoid storing the battery after discharging. If the battery is to be left for several days or more, make certain that it is charged before storage. The optimum environment for batteries is to charge while stored. The type of charger used in the indicator will not damage the batteries in any way even if the battery is left charging indefinitely.

APPENDIX A – ANALOG OUTPUT OPTION (DAC) BOARD

This appendix describes the installation, setup and calibration of the optional Analog Output Option DAC (Digital to Analog Converter) board. This option consists of both a 0 to 10 volt and 4 to 20 mA analog output.

The Analog Output Option (DAC) board (Cardinal p/n 8200-C210-0A) is a 14-bit (16,383 states) analog representation of the displayed weight. The maximum load resistance for the current output is 500 ohms. The minimum load resistance for the voltage output is 2K ohms. Connections are made via a terminal block on the back of the option board. Refer to Figure No. 12 for the connector pin layout.

The 205/210 indicators feature complete "ranging" for DAC output. Users may select a weight range to be used for a selectable voltage range. This covers all current indicators/users and expands the capabilities for new applications. The 205/210 indicators also have auto-detect for option board installation. When the DAC board is found, additional prompts will be added to Setup. The main menu adds "dAC" (dAC?) after "LoCoUt". In addition, the calibration sequence includes the steps necessary to calibrate the analog output.

INSTALLATION

Mounting the DAC Board

NOTE! Should your indicator come with the DAC board already installed, the following information describing the mounting of the board does not apply. Proceed to the Cable Installation section.

1. Make sure the power to the indicator is OFF. Unplug the AC adapter and/or remove the battery.
2. Remove the 12 acorn nuts securing the back panel to the main housing.
3. Lift the back panel from the main housing, taking care not to stretch the cable and wires between the panel and main housing.
4. Locate the threaded mounting stud (below J2) and connector P5 on the main board.
5. To install the DAC board, carefully align the DAC board P1 (pins on trace side of DAC board) with connector P5 on the main board.
6. Align the hole in the DAC board with the threaded mounting stud (below J2) on the main board.
7. Apply even downward pressure to the end of the DAC board with P1.
8. Using the lock washer and hex nut supplied with the DAC board, secure the DAC board to the main board.

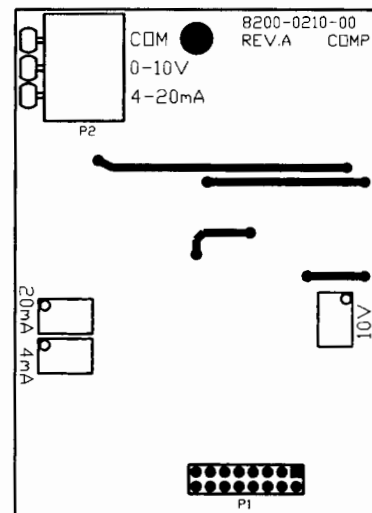

Figure No. 12 - DAC (Rear View)

Cable Installation

1. Loosen a cable gland connector for the Analog Output cable.
2. The gland connector(s) are on the enclosure rear panel.
3. Slip a two wire cable through the gland connector and into the enclosure.
4. Remove 2" of the outer insulation jacket then remove 1/4" of insulation from each of the wires.
5. Connect each of the wires to the terminal block (P2).
6. To terminate, first press down on the release bar for the terminal, insert the wire into the opening then allow the release bar to return to its original position, locking the wire in place. Repeat the procedure until all wires are in place.

P2 TERMINAL BLOCK

PIN NO.	Function
COM	Common
0-10V	0 to 10 volt output (2K Ω Min. Load)
4-20 mA	4 to 20 mA current output (500 Ω Max. Load)

CALIBRATION of the ANALOG OUTPUT

The analog output has been calibrated at the factory and should require no other adjustment. If, for some reason, it is found necessary or desirable to readjust this output, the procedure listed below may be used. In order to calibrate the analog output, it is first necessary to enter the Calibration mode by gaining access to the calibration switch. Refer to the Setup and Calibration section of this manual for additional information.

The following questions in the “dAC” section apply only if the board is installed.

dAC (dAC?) – Digital to Analog Converter

With dAC? displayed, press the **ENTER** key. The display will change to show Lo=.

Lo=

Press the **ENTER** key to show the stored value. This is the value, in weight, which outputs zero volts (or 4 mA) from the “dAC”. All weight below this target will output zero volts (or 4 mA). If the setting is acceptable, press the **ENTER** key again to save it. Otherwise, using the numeric keys enter the desired weight value, then press the **ENTER** key to save it. The **NET/GROSS** key will change the weight sign. For example, to input -1000 as the weight value, press 1 0 0 0 **NET**. Allowable values are: -99999 to 999999.

Hi=

Press the **ENTER** key to show the stored value. This is the value, in weight, which outputs the maximum selected voltage and current (see oUt=). All weights above this value will output maximum volts from the “dAC”. If the setting is acceptable, press the **ENTER** key again to save it. Otherwise, using the numeric keys enter the desired weight value, then press the **ENTER** key to save it. This weight must be a positive value, up to capacity of scale, and above the Lo= value. Allowable values are: 1 to 999999.

oUt=

Press the **ENTER** key to show the stored value. This is the maximum output value in volts (00.01 to 10.00). All weight values equal to or greater than “Hi=” will output this value. Note, that if the scale goes OCAP (over capacity), this value is used also. If the setting is acceptable, press the **ENTER** key again to save it. Otherwise, using the numeric keys enter the desired, then press the **ENTER** key to save it. Allowable values are: 00.01 to 10.00.

NOTE! If the 4 to 20 mA current output is to be used, set “oUt=” to: $10x \frac{(\text{max current} - 4)}{16}$

$$\text{Current} = \frac{\text{“oUt=”}}{10} \times 16 + 4 \text{ (mA)} \quad (\text{Can not be greater than 20 mA})$$

Adj Hi

This sets the “dAC” output to “oUt=” level for adjusting the level. Adjustment potentiometers “pots” (10V and 20 mA) on the option board are used.

- Adjust the 10V pot for the maximum voltage output entered for “oUt=”.
- For 4 to 20 mA current output, adjust the 20mA pot for the calculated maximum current.

Press **ENTER** key to proceed to “Adj Lo”, or the **ASTERISK** key to return to the previous prompt.

Adj Lo

This sets the “dAC” output to zero for adjusting the level. Adjustment “pots” (10V and 4 mA) on the option board are used.

- There is no adjustment for zero volts out.
- For 4 to 20 mA current output, adjust the 4mA pot for the low (4 mA) current output.

Press the **ASTERISK** key to return to “Adj Hi”, or the **ENTER** key to return to the SEtUP prompt

CALIBRATION of the ANALOG OUTPUT, Cont.



NOTE! *Cycling between “Adj Hi” and “Adj Lo” is necessary when adjusting the current out. This must be repeated until no adjustment is necessary.*

RE-INSTALLING THE REAR PANEL

After all terminations have been made, remove the excess cable from the instrument enclosure and securely tighten each of the cable gland connectors. Do not over-tighten these connectors but make certain they are snug. **DO NOT USE TOOLS!** Finger tighten only! Insure any unused gland connectors are plugged.

Make certain no cables or wires are exposed between the main housing and rear panel then place the rear panel onto the main housing. Secure with the 12 acorn nuts removed earlier.

NOTE! Follow a diagonal pattern when tightening the acorn nuts.

PART IDENTIFICATION

(Rear Enclosure Sub Assembly)

ITEM NO.	QTY.	PART NUMBER	DESCRIPTION
1	8	6013-0039	HEX NUT #6-32
2	4	6013-0245	HEX NUT #4-40
3	2	6021-0654	SCW PAN HEAD #6-32 x .250 PDMS
4	1	6021-1108	SCW FILLISTER MACHINE-SCW #10-32 x .375 S.S.
5	4	6024-0108	WASHER LOCK INT. TOOTH #4 S.S.
6	1	6024-1081	WASHER FLAT #10 NEOPRENE BACKING S.S.
7	4	6540-1104	PLUG, HOLE 0.173-.240 RED POLYETH
8	5	6610-2248	GLAND CONNECTOR
9	1	6610-5007	CABLE CLIP
10	10	6680-0004	WASHER LOCK INT. TOOTH #6 Z/P
11	4	6680-0138	SPACER #6 x .187 NYLON
12	1	6680-0200	POP RIVET
13	2	6680-0203	SPACER (PCB) #6-32 x .500
14	1	6800-1033	POWER SUPPLY BOARD
15	2	6980-0014	WIRE TIE 4" BLACK
16	1	6980-1030	POWER CORD 18/3 SVT CEE 6.3 FT
17	1	8200-B019-08	BRACKET: CALIBRATION SWITCH
18	1	8200-B104-08	LABEL: 205/210 TERM. BLOCK
19	1	8200-B204-0A	CABLE: 205/210 POWER SUPPLY OUTPUT
20	1	8200-B205-0A	CABLE: 205/210 BATTERY CABLE
21	1	8200-B212-0A	CABLE: GND
22	1	8200-B215-0A	CABLE: AC POWER W/FILTER 205/210 DWI
23	1	8200-C012-08	BRACKET, BATTERY HOLDER
24	1	8200-C016-0A	WELDMENT: ENCLOSURE REAR
25	1	8200-C018-08	POWER SUPPLY COVER
26	1	8510-C346-0I	LABEL - HIGH VOLTAGE
27	1	8512-B350-0A	WIRE: 18GA, GRN, 5.0, #8RT/TINNED
28	1	8200-B206-0A	BATTERY POWER BOARD
29	1	8526-B232-08	SPRING, BATTERY COVER
30	1	8539-B254-0A	ASSEMBLY: CABLE, CALIBRATION SWITCH

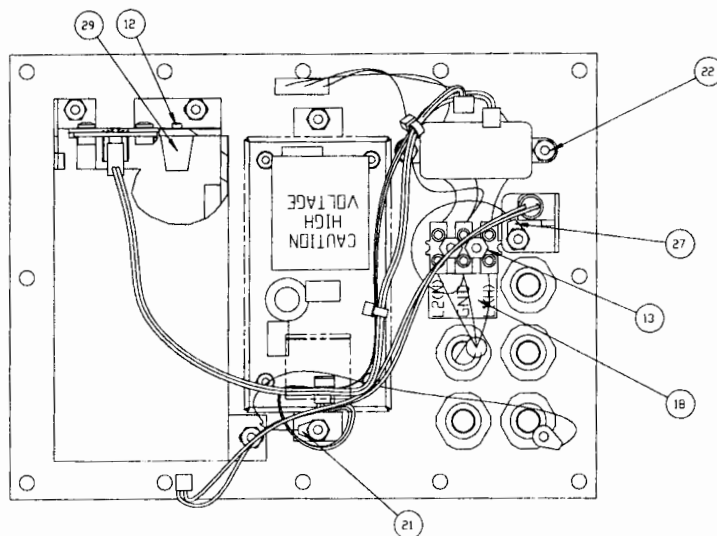

PART IDENTIFICATION

(Rear Enclosure Sub Assembly)

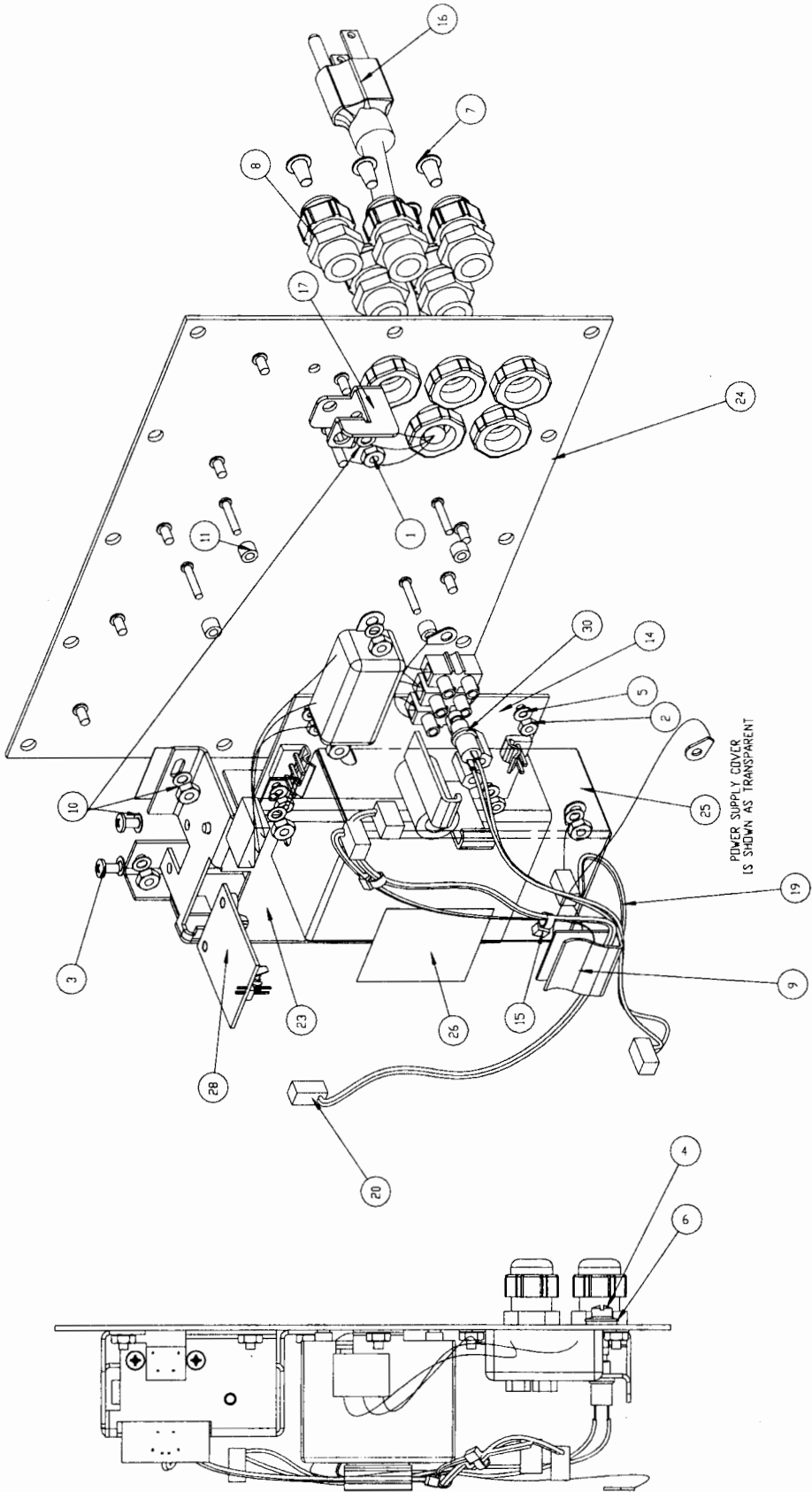

PART IDENTIFICATION

(Front Enclosure Sub Assembly)

ITEM NO.	QTY.	QTY.	PART NUMBER	DESCRIPTION
	205	210		
1	14	14	6013-0039	NUT HEX #6-32
2	1	1	6013-0297	NUT 10-32 HEX
3	3	3	6013-0433	NUT HEX #10-32 ACORN S.S.
4	1	1	6021-0623	SCW PAN HEAD #6-32 x .750 PDMS
5	10	10	6024-1078	WASHER FLAT #6 NEOPRENE BACKING S.S.
6	1	1	6560-0064	DESSICCANT 1 x 1 BAG
7	1	1	6610-5002	GROUND LUG
8	3	3	6610-5007	CABLE CLIP
9	4	4	6680-0004	WASHER LOCK INT. TOOTH #6 Z/P
10	4	4	6680-1049	SPACER (PCB) #6 x .438
11	1	1	6710-1017	TAPE DBL SIDED 1.0 WIDE 45 MIL THK.
12	1	1	8200-B014-08	GASKET FOR 210 ENCLOSURE
13	1	1	8200-B020-08	COVER, BATTERY
14	1	1	8200-B021-08	GASKET: BATTERY DOOR
15	1	1	8200-C015-0A	WELDMENT: BEZEL FOR 210
16	1	1	8200-C017-0A	WELDMENT: ENCLOSURE, FRONT
17			8200-C201-0A	DAC PCB (OPTIONAL)
18	1		8200-D100-08	KEYPAD: 205 DWI
19	1		8200-D201-0A	PC BD, ASSY. 205 MAIN
20		1	8200-D201-1A	PC BD, ASSY. 210 MAIN
21		1	8200-D202-08	KEYPAD: 210 DWI

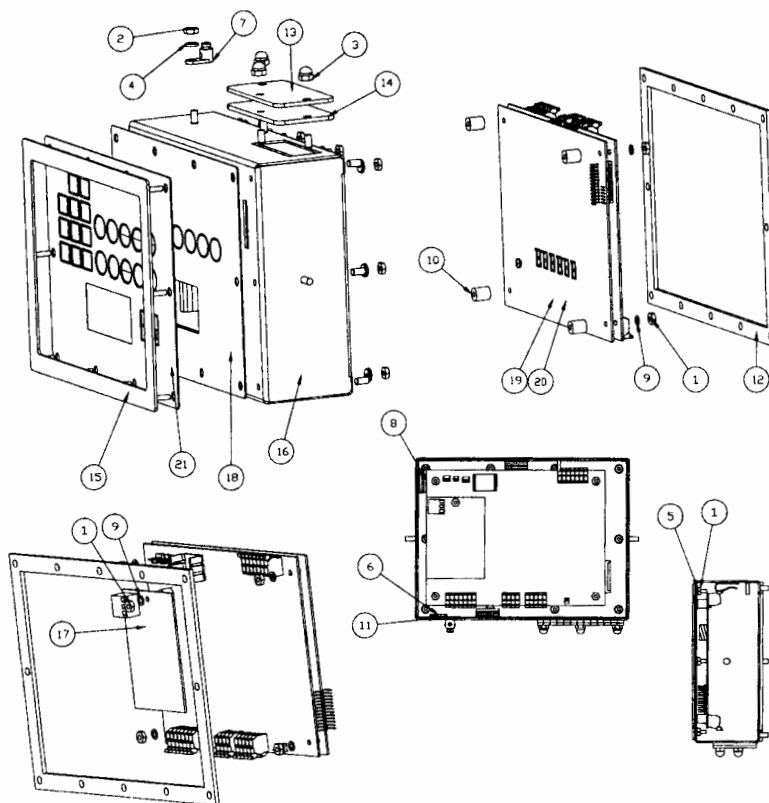

PART IDENTIFICATION

(Final Assembly)

ITEM NO.	QTY.	QTY.	PART NUMBER	DESCRIPTION
	205	210		
1	1	1	593GR986	SERIAL TAG ASSEMBLY
2	11	11	6013-0433	NUT HEX #10-32 ACORN S.S.
3	1	1	6650-0087	LABEL: MADE IN THE USA
4	1	1	8200-B026-08	NUT HEX #10-32 ACORN S.S. DRILLED
5	1	1	8200-D207-0A	SUB ASSEMBLY: REAR ENCLOSURE
6		1	8200-D208-0A	SUB ASSEMBLY: FRONT
8	1		8200-D208-1A	SUB ASSEMBLY: FRONT 205

